

# The Differences are Not So Great: High Altitude Balloon and Small Spacecraft Software Development

Jeremy Straub and Ronald Marsh

*Department of Computer Science, University of North Dakota, Grand Forks, ND 58202 USA*

**Previous work discussed critical differences in planning, developing hardware for and executing a high altitude balloon (HAB) mission. One area where this difference is less pronounced is in software development, allowing HABs to be utilized as a ‘software testbed’ for many orbital missions. This paper provides an overview of the software development process for both orbital and HAB craft, highlighting differences between the two processes and the numerous similarities. It concludes by presenting a framework for analyzing the suitability of HAB testing for small satellite software.**

## I. Introduction

**P**REVIOUS work<sup>1</sup> discussed critical differences between the planning, developing and execution of a high altitude balloon (HAB) mission and an orbital spacecraft. Therein, it was contended that HABs should not be regarded as lower cost versions of an orbital satellite, but instead developed in light of their own characteristics (which, comparatively, enable some types of missions, while impeding others). One area where this difference is less pronounced is in software development, allowing HABs to be utilized as a ‘software testbed’ for many orbital missions.

This paper provides an overview of the software development process for both orbital and HAB craft, highlighting differences between the two processes and the numerous similarities. The utility of the HAB for enabling software testing in preparation for an orbital mission (or in augmentation or replacement of an orbital mission) is considered in light of three different mission concepts. The first is a short-term Earth sensing mission for identifying anomalies between an a priori model of a geological feature and real world conditions. The second is a longer-term mission to collect imagery for use in a digital aerial imagery product. The third is a mission in support of a prospective homeland security operation. The different characteristics of these missions are used to highlight areas where a HAB mission is fundamentally different from an orbital mission and characterize the impact of these differences on the software developed and testing.

The paper concludes by presenting a framework for analyzing the suitability of HAB testing for small satellite software. While generally concluding that this (HAB to satellite) progression is beneficial, several key pitfalls are highlighted. The prospective educational benefits (in the context of academic projects) from this approach area also discussed.

## II. Background

HAB missions fill a niche between comparatively lower-altitude aerial and orbital craft, making mission access to a range of altitudes available at very low cost. Unlike manned and unmanned aircraft, little control can be exerted over the flight path of a HAB (with the limited control possible being primarily determining when/where to detach the payload from the balloon). Balloons also reach altitudes of as high as 42 km (based on a zero-pressure balloon<sup>2</sup>, latex and super-pressure<sup>3</sup> balloons reach altitudes in the 30 km neighborhood, while solar balloons may reach 15 to 20 km<sup>4-6</sup>). Orbital spacecraft, on the other hand, operate at higher altitudes, as the mission life for spacecraft even as low as 300 km is quite short (in the absence of a propulsion system for orbit raising)<sup>7</sup>. In a given week, with balloons being launched from weather stations at approximately 700 locations worldwide, two times per day, there are more HAB launches than there have ever been satellites launched<sup>8-10</sup>.

This history of high altitude ballooning reaches back several decades<sup>11</sup>. Aside from their well-known work on atmospheric condition measurement and weather prediction, HABs have served numerous other purposes. The Absolute Radiometer for Cosmology, Astrophysics, and Diffuse Emission (ARCADE) program<sup>12</sup> sought to characterize the Big Bang through the measurement of radiation from the first stars it created. The Balloon-Borne Large-Aperture Sub-Millimeter Telescope (BLAST)<sup>13, 14</sup> also scanned upward: it collected information regarding

star and planet formation. Missions such as the SAGE III Ozone Loss and Validation Experiment (SOLVE)<sup>15</sup> demonstrate the efficacy of utilizing HABs for Earth sensing. SOLVE, for example, collected measurements to characterize the production and loss of ozone. Balloons have also been utilized to deploy communications networks<sup>16, 17</sup>.

The use of high altitude balloons in education and academic research has also been demonstrated. Their use has been shown in the context of teaching space mission design<sup>18, 19</sup> and facilitating student engineering exploration<sup>20</sup>. Programs have been proposed<sup>21</sup> and conducted<sup>22, 23</sup> at the K-12 level as well as to engage and enrich the education of university students<sup>24, 25</sup>. In this context, a framework for the design of HAB missions has been proposed<sup>1</sup>, which draws on and is aligned with common methodologies<sup>7, 26, 27</sup> utilized for space missions. This framework highlighted the need to design a HAB mission in its own context, instead of as a scaled down space mission (or avoiding design altogether). A set of standards<sup>28, 29</sup> for academic and other HAB use has also been proposed.

### III. Overview of Software Development Process for HAB and Orbital Missions

A wide variety of software development processes have been proposed. These range from methods such as the perhaps aptly-named “big bang” approach<sup>30</sup> (which seeks to achieve all goals in one large release) and the commonly-used waterfall approach<sup>31, 32</sup> (which presumes an orderly progression from requirements identification, through design and implementation and to verification and ongoing maintenance), to methods and processes which promote iterative design<sup>33</sup>, customer responsiveness and adaptability<sup>34</sup>. An extended discussion of software development methods is beyond the scope of this paper (and already dealt with in numerous other papers, such as [32]). For simplicity, the waterfall model will be utilized, realizing that in reality this process that is presented in a linear fashion may actually be comprised of multiple iterations of the define requirements, design, implement and verify cycle. Space mission design and, to a lesser extent because of relaxed constraints in some areas, HAB mission design is inherently iterative, as changes to one area of the spacecraft/payload may cause constraint or requirement violations necessitating changes in other areas to compensate. Figure 1(a) provides a basic overview of the waterfall model and Figure 1(b) shows an adaptation to the more realistic iterative approach.

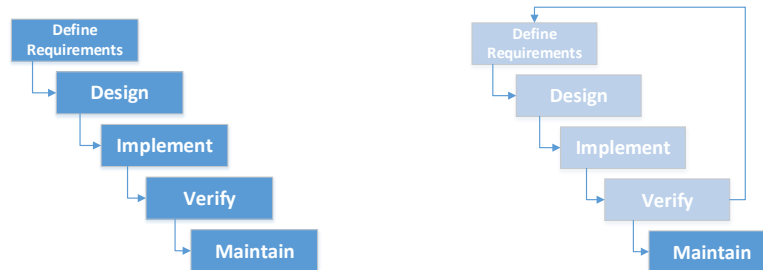

Figure 1. (a) Waterfall model of software development (left, simplified from [35]), (b) Adapted iterative waterfall model of software development (right).

### IV. Mission Concept Case Studies

Three mission concepts are now presented to facilitate discussion of the utility of the use of a HAB mission for testing software designed and destined for orbit. This section (IV) presents a brief overview of the three cases, while the next (V) provides the discussion of HAB utility. The three concepts presented are a short-term Earth sensing mission, a longer-term imagery collection mission and a homeland security ongoing operation.

#### A. Short-term Earth Sensing Mission

Previous work<sup>36</sup> has discussed the utility of comparison to an a priori model as a method for creating low-cost space missions. Given that small spacecraft<sup>37</sup> and technical advances have increased data collection capabilities, while being unable to affect the physical laws that define antenna gain and power generation and limit communications capabilities, a disparity exists between collection and transmission capabilities. By sending the craft up with a model of the current knowledge of a phenomena and allowing it to transmit updates, communications requirements are reduced. This case is such a mission, with small spacecraft utilized to collect and process data for transmission to Earth

Relevant differences between a prospective HAB test mission and planned orbital mission include: (1) differences in sensing resolution and imaging area (from altitude), (2) differences in spacecraft vs. HAB ground track, (3) differences in craft motion and greater levels of attitude change and (4) differences in communications

windows. Similarities include: (1) hardware utilized, and (2) mission power cycle (in that the HAB mission is covering basically one cycle of the orbital mission).

### **B. Long-Term Digital Imagery Collection Mission**

The second case study deals with a longer-term mission to collect imagery for a digital repository. The constellation and operations of Planet Labs<sup>38</sup> is one example of this type of a mission. The company aims to use a constellation of 28 small spacecraft to collect imagery of the whole earth that “is unmatched in its breadth and freshness”<sup>38</sup>. A prospective HAB test mission for this type of application would facilitate the testing of the onboard software using analog hardware, over a very limited subset of the target area of operations.

Differences between the HAB test mission and planned orbital mission include: (1) differences in optical resolution and imaging area (from altitude), (2) differences in spacecraft vs. HAB ground track, and (3) differences in communications windows. Similarities include: (1) hardware utilized, and (2) mission power cycle (in that the HAB mission is covering basically one cycle of the orbital mission).

### **C. Mission in Support of Homeland Security Operations**

The third case study deals with a scenario where a HAB mission could be utilized to simulate an ongoing operation in a homeland security context (i.e., collecting imagery that will be analyzed for threat detection). A primary distinction for this mission is that the space system will operate on an ongoing basis (effectively until an end-of-life condition is reached for the spacecraft). It is presumed that this mission incorporates both steerable visible light and infrared sensing hardware. The orbital spacecraft will also be significantly larger than the HAB payload which is being utilized for software testing.

Differences between the HAB test mission and planned orbital operations include: (1) differences in optical resolution and imaging area (from altitude), (2) differences in spacecraft vs. HAB ground track, (3) differences in communications windows, (4) significant differences in the power utilized and (5) significant differences in length of operations without resetting event. Similarities include the mission’s power cycle (in that the HAB mission is covering basically one cycle of the orbital mission).

## **V. Discussion of HAB Mission Utility for Testing Orbital Software**

The three case studies serve to highlight both the benefits and possible drawbacks of utilizing a HAB mission for testing software destined for orbit. The primary benefit from the use of the HAB is low-cost access to comparatively high altitudes. Ancillary benefits (which are ancillary primarily because they can be simulated without significant difficulty) include (very limited, unless communications windows are considered) communications latency and potentially (depending on the HAB to ground communication approach utilized\*) limited (albeit irregular) communications windows. For two of the three missions the actual mission hardware or substantially similar hardware can be utilized in the testing environment, facilitating greater accuracy of testing results. The power cycle is also similar in all three cases; however, this could effectively be tested on the ground and thus is not as significant of a benefit for most operations.

Issues with this testing approach, for all three missions, stem from the difference between HAB and orbital operations. The HAB doesn’t have the deterministic orbit of a satellite; nor is it guaranteed to overfly any particular area. This latter limitation can be particularly problematic if testing requires that the payload image (or otherwise overfly) a particular phenomenon or an area of known characteristics. Depending on the altitude, HAB payloads may also experience significantly more attitude instability, due to being acted upon by atmospheric phenomena. Given the lower altitude, the resolution and frame-of-view for a HAB mission using the same hardware and settings is different from an orbital mission. This may dictate changes to the software to compensate for this difference, which may lead to areas of code that are disabled/not tested during the HAB-based testing. An alternate approach may, thus, be required for testing these areas of code. This may simply increase testing expense or, in some cases, make the HAB-based testing duplicative. The difference between the deterministic ground track and communications windows of an orbital craft and the irregular ones of a HAB may create similar needs to disable and alternately test code related to these areas, as well.

The mission duration may also be problematic, particularly for case 3 (but to a lesser and similar extent for the other cases) as its short timespan may fail to detect defects which are only apparent over long periods of operation

---

\* The existence of communications windows for HAB communications presumes that the HAB will be out of range of ground stations during points of its flight. This assumption is not necessarily accurate for many communications approaches.

(e.g., a memory leak). While ground-based long-duration testing can be performed, this may lack the inputs necessary to trigger these latent errors, potentially driving a need for simulation (and potentially making the HAB-based testing redundant). The differences in hardware and computational capabilities, for case 3, may also be problematic. The differences in the radiation environment and other environmental factors may also limit the utility of testing software responses to and survivability across phenomena such as single even upsets (SEUs).

## VI. Framework for Analyzing HAB Mission Suitability

A framework is presented in Figure 2 for analyzing the suitability of a HAB mission for testing and validating software that is targeted at an orbital environment. This framework considers five components to HAB mission suitability: hardware, ground track, resolution/field-of-view, attitude and operations. For each of these five areas, the differences (representing prospective drawbacks and costs) and similarities (representing prospective benefits) are considered. A likelihood modifier could also be added to each prospective difference/cost and similarity/benefit if it is uncertain whether this difference/cost or similarity/benefit will be attained, allowing a likelihood-modified cost/benefit analysis to be conducted.

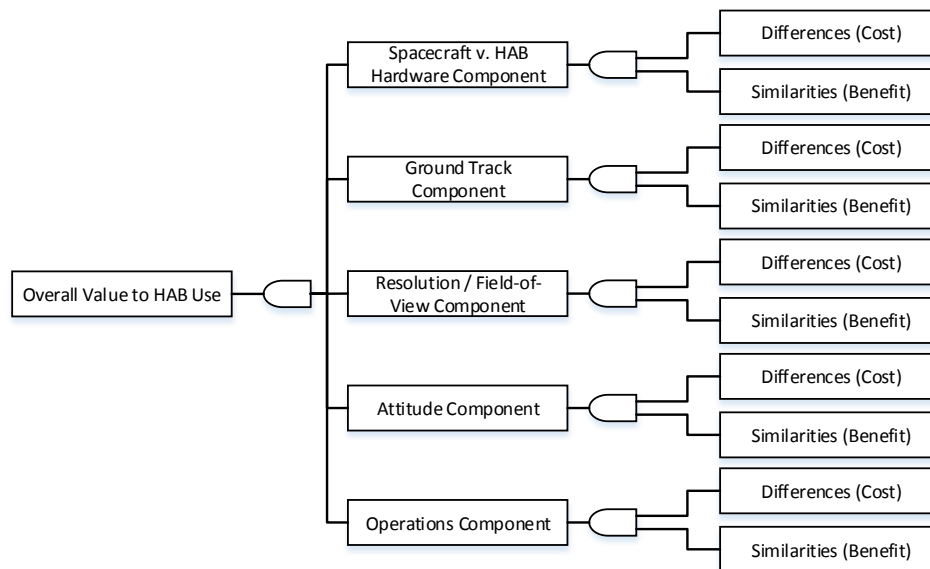

Figure 2. Framework for Analyzing HAB Mission Suitability.

A brief discussion of each component is now called for. The following highlights considerations for each area:

- **Spacecraft vs. HAB Hardware** – Similarities and differences in hardware configurations which impact the ability to test the desired elements of the software should be considered. Particular attention should be paid to hardware elements which necessitate the replacement or disablement of code that will need to be otherwise tested.
- **Ground Track** – Similarities and differences in the ground track of the spacecraft (deterministic) and HAB (erratic) should be considered. The impact of this on data collection, mission operations, communications and whether objects / areas of interest are overflowed should be considered. Particular attention should be paid to whether differences necessitate the replacement or disablement of code that will need to be otherwise tested.
- **Resolution / Field-of-View** – Similarities and differences in the resolution and field-of-view of imagery or other data that will be collected / processed should be considered. The impact of this on testing data processing code, in particular, should be evaluated. Particular attention should be paid to whether differences necessitate the replacement or disablement of code that will need to be otherwise tested.
- **Attitude Component** – The impact of the erratic movement and attitude of the HAB versus the greater stability of the orbital spacecraft should be considered. Particular attention should be paid to whether differences necessitate the replacement or disablement of code that will need to be otherwise tested.

- Operations Component – The impact of the dramatically different timeframe, nature and scope of operations between the HAB and spacecraft should be considered. Particular attention should be paid to whether differences necessitate the replacement or disablement of code that will need to be otherwise tested.

The proposed framework can be utilized both for summative and formative evaluation. From a summative perspective, its use is quite simple, the benefits and drawbacks of the approach are assessed (and any relevant modifiers applied) and a decision is made. The framework's use from a formative perspective is more complicated, as areas that appear to have excess cost or insufficient benefit could indicate potential opportunities for mission redesign for value-as-a-function-of-cost maximization. Given that modifications in one area may (and in many cases do) effect decisions in other design areas, a sequential network may be able to be derived to evaluate the impact of different changes. This is similar to sequential game theory, except without an opponent per se. Instead, the additional changes dictated by requirements and constraints can be evaluated, based on projecting different decisions in response to requirements and constraints (and the flow-down effects thereof) to ascertain the cost and benefit impact of prospective changes.

## VII. Prospective Educational Benefits

One area where HABs excel, from a software development perspective, is education. In this regard, they provide another key benefit, which may not be as relevant to non-educational missions. They facilitate student conceptualization of the mission. Going through a properly designed HAB mission cycle (using the design techniques proposed in [1] or elsewhere), allows students to understand the process. Similarly, the in-air operations of the HAB allow students to understand the difficulties and considerations of later on-orbit spacecraft operations. Like in other areas (e.g., mission design<sup>18</sup>), the HAB experience can aid students in understanding the aerospace software development process. This exposure can also help 'buy down' the significant risk that comes from student inexperience and other factors<sup>39</sup>. A more detailed discussion of this topic can be found in [40].

## VIII. Conclusions

This paper has presented a discussion of the utility of using HAB missions for the testing and validation of software destined for orbital operations. It has discussed the benefits and potential drawbacks of this approach. A limited framework for evaluating HAB mission suitability has been presented. The paper has concluded that while HAB testing of software that is targeted at satellite use may not make sense in many areas (and the approaches suggested in [41] may be better suited), one area of particular utility is in education. In education, the ability to facilitate student understanding, provide software development and mission lifecycle exposure within a limited period of time and the inherent team building benefits of HAB operations (particularly for HAB that must be tracked and recovered) make the use of HAB missions well justified. The experience gained from this, by the student participants and faculty alike, can be directly applied to success in orbit, even if the HAB mission is not a comprehensive testing solution for the software.

## Acknowledgments

Facilities and resources relevant to the creation of this paper have been provided by the University of North Dakota Department of Computer Science, North Dakota EPSCoR (NSF # EPS-814442) and the UND Faculty Seed Money Committee.

## References

- <sup>1</sup>Straub, J. and Fevig, R., "Formalizing Mission Analysis and Design Techniques for High Altitude Ballooning," Proceedings of the 3rd Annual High Altitude Conference (2012).
- <sup>2</sup>Johnson, M. , "Scientific Balloons," (2013).
- <sup>3</sup>NASA Wallops Flight Facility , "Code 820 Super Pressure," 2012 (2008).
- <sup>4</sup>Boehme, J., [Fly Solar Balloons: Everything You Want to Know about Making and Flying Your Own], Solar-Balloons.com (2009).
- <sup>5</sup>Nordlie, J., Straub, J., Theisen, C. and Marsh, R., "Solar Ballooning: A Low-Cost Alternative to Helium Balloons for Small Spacecraft Testing," AIAA Science and Technology Forum and Exposition (SciTech 2014) (2014).

- <sup>6</sup>Nordlie, J., Straub, J., Theisen, C. and Marsh, R., "The Use of Solar Balloons at UND as a Low-Cost Alternative to Helium Balloons for Small Spacecraft Testing and STEM Education," University of North Dakota Graduate School Scholarly Forum (2014).
- <sup>7</sup>Larson, W. J. and Wertz, J. R., [Space Mission Analysis and Design, 3rd Edition], Microcosm Press, Hawthorne, CA (1999).
- <sup>8</sup>National Weather Service Forecast Office in Reno, NV , "Upper-Air Program Virtual Tour," 2012 (n.d.).
- <sup>9</sup>Lafleur, C. , "Spacecraft Encyclopedia," 2012 (2011).
- <sup>10</sup>NOAA National Weather Service , "Radiosonde Observations," 2012 (n.d.).
- <sup>11</sup>U.S. Centennial of Flight Commission , "Early Scientific Balloons," 2012 (n.d.).
- <sup>12</sup>NASA Goddard Space Flight Center , "Absolute Radiometer for Cosmology, Astrophysics, and Diffuse Emission," 2012 (2012).
- <sup>13</sup>Devlin, M. , "Balloon-borne Large-Aperture Submillimeter Telescope," n.d. (n.d.).
- <sup>14</sup>Pascale, E., Ade, P., Bock, J., Chapin, E., Chung, J., Devlin, M., Dicker, S., Griffin, M., Gundersen, J. and Halpern, M. , "The Balloon-borne large aperture submillimeter telescope: BLAST," *Astrophys.J.* 681(1), 400 (2008).
- <sup>15</sup>Newman, P. , "SAGE III Ozone Loss and Validation Experiment, SOLVE A NASA DC-8, ER-2 and High Altitude Balloon Mission," 2012 (1999).
- <sup>16</sup>Hariyanto, H., Santoso, H. and Widiawan, A. K., "Emergency broadband access network using low altitude platform," *Instrumentation, Communications, Information Technology, and Biomedical Engineering (ICICI-BME), 2009 International Conference on*, 1-6 (2009).
- <sup>17</sup>Vilhar, A., Hrovat, A., Javornik, T. and Mohorcic, M., "Experimental analysis of wireless temporary networks deployed by low altitude platforms," *Computer Aided Modeling and Design of Communication Links and Networks (CAMAD), 2013 IEEE 18th International Workshop on*, 238-242 (2013).
- <sup>18</sup>Fevig, R. and Nordlie, J., "Augmenting a Space Mission Design Course with High-Altitude Balloon Projects," *Proceedings of the 2nd Annual Academic High Altitude Conference* (2011).
- <sup>19</sup>Nordlie, J. and Fevig, R., "Blending research and teaching through high-altitude balloon projects," *Proceedings of the 2nd Annual Academic High Altitude Conference* (2011).
- <sup>20</sup>Fevig, R., "Student aerospace engineering projects and educational programs at the University of North Dakota," *Proceedings of the 2009 ASEE North Midwest Sectional Conference* (2009).
- <sup>21</sup>Straub, J., Ingwalson, G. and Fevig, R. , "A Design for Inspiring Students with Near-Space Exploration," *Journal of Aviation/Aerospace Education and Research* 23(1), 35-48 (2013).
- <sup>22</sup>Saad, M., "Providing Hands-on STEM Education with High Altitude Balloons in North Dakota," *Proceedings of the Academic High Altitude Conference* (2013).
- <sup>23</sup>Jackson, K., Fevig, R. and Seelan, S., "North Dakota State-Wide High Altitude Balloon Student Payload Competition," *The Proceedings of the 3rd Annual Academic High Altitude Conference* (2012).
- <sup>24</sup>Straub, J. and Fevig, R. , "Achieving Educational Outcomes Through CubeSat Curriculum Incorporation," (2012).
- <sup>25</sup>Straub, J. and Fevig, R., "The North Dakota Space Robotics Program: Teaching Spacecraft Development Skills to Students Statewide with High Altitude Ballooning," *Proceedings of the 2012 Academic High Altitude Conference* (2012).
- <sup>26</sup>Wertz, J. R., Everett, D. F. and Puschell, J. J., [Space Mission Engineering: The New SMAD], Microcosm Press, Hawthorne, CA (2011).
- <sup>27</sup>Fortescue, P., Swinerd, G. and Stark, J., [Spacecraft Systems Engineering], Wiley (2011).
- <sup>28</sup>Straub, J., Nordlie, J. and Anderson, E. , "A Need for Operating Standards in the Academic and Research High Altitude Balloon Community," *Issues in Aviation Law and Policy* 12(3) (2013).
- <sup>29</sup>Straub, J., Nordlie, J. and Anderson, E., "Operating Standards for the High Altitude Ballooning Community," *2013 Academic High Altitude Conference* (2013).
- <sup>30</sup>Redmill, F., [Software Projects: Evolutionary Vs. Big-Bang Delivery], John Wiley & Sons, Inc. (1997).
- <sup>31</sup>Laplante, P. A. and Neill, C. J. , "The demise of the Waterfall model is imminent," *Queue* 1(10), 10 (2004).
- <sup>32</sup>Davis, A. M., Bersoff, E. H. and Comer, E. R. , "A strategy for comparing alternative software development life cycle models," *Software Engineering, IEEE Transactions on* 14(10), 1453-1461 (1988).
- <sup>33</sup>Boehm, B. W. , "A spiral model of software development and enhancement," *Computer* 21(5), 61-72 (1988).
- <sup>34</sup>Martin, R. C., [Agile Software Development: Principles, Patterns, and Practices], Prentice Hall PTR (2003).
- <sup>35</sup>Cusumano, M. A. and Smith, S. A. , "Beyond the waterfall: Software development at Microsoft," (1995).
- <sup>36</sup>Straub, J. , "Application of Model-Based Data Transmission Techniques to Gravitational Model Data," *Journal of Data Analysis and Information Processing* 1(3), 46-57 (2013).

<sup>37</sup>Straub, J., "Cubesats: A Low-Cost, Very High-Return Space Technology," Proceedings of the 2012 Reinventing Space Conference (2012).

<sup>38</sup>Planet Labs , "Flock 1," Planet Labs Website 2014 (n.d.).

<sup>39</sup>Straub, J., Fevig, R., Casler, J. and Yadav, O., "Risk Analysis & Management in Student-Centered Spacecraft Development Projects," Proceedings of the 2013 Reliability and Maintainability Symposium (2013).

<sup>40</sup>Straub, J. , "Evaluation of High-Altitude Balloons as a Learning Technology," International Journal of Learning Technology (in press).

<sup>41</sup>Straub, J. , "A Comparison of Learning Technologies for Teaching Spacecraft Software Development," Journal of Educational Technology Systems (in press).