

Introgressing Multiple Quantitative Trait Loci through Backcross Breeding Programs

Napapan Chaiwong, Ph.D. student
 Jack C.M. Dekkers, Professor
 Rohan L. Fernando, Professor
 and Max F. Rothschild, Distinguished Professor
 Department of Animal Science

ASL-R1802

Summary

The ability to introduce favorable alleles for multiple genes from a donor breed into a commercial breed through a backcross program of limited size was evaluated. The effects of fraction selected, marker interval, and number of quantitative trait loci were considered. Informative flanking markers were used to select progeny with the largest expected number of recipient QTL alleles for 5 generations. With $\leq 5\%$ selected, sufficient progeny were available that were heterozygous for all markers at three QTL and QTL frequencies remained close to 50%. For larger fractions selected, larger marker intervals, and more QTL, reductions from 50% frequencies were greater and increased over generations. However, even with 20% selected, three QTL and marker intervals of 5 or 20 cM, mean QTL frequencies in generation 5 were 35 and 30%, which was sufficient to allow subsequent selection to fix the QTL. This indicates that it is possible to introduce multiple favorable QTL alleles into a commercial breed. The optimal breeding and selection strategy and the economic feasibility of such an approach requires further analysis, which is underway.

Introduction

Recent breed cross studies have found several genes for economic traits (quantitative trait loci), that segregate between breeds. For example, an F2 crosses between Berkshire and Yorkshire grandparents identified several favorable QTL for meat quality in the Berkshire breed, which has undesirable growth performance (2,3). It is, therefore, of great interest to develop strategies to incorporate desirable QTL alleles from the Berkshire (donor breed) into the Yorkshire breed (recipient breed).

Introgression involves two successive phases (Fig. 1): a backcrossing phase and an intercrossing phase. The aim of the backcrossing phase is to generate individuals that carry one copy of the donor QTL allele but that are similar to the recipient breed for the rest of the genome. This is accomplished by successive backcrosses to the recipient breed to "dilute" the donor genome, while

maintaining the donor allele at the QTL by selecting only carriers as parents of the next generation. The aim of the intercrossing phase is to fix the donor allele at the QTL. The end result is a population that is similar to the recipient breed, except for carrying two copies of the donor allele at the QTL.

In most cases, the QTL that is to be introgressed cannot be genotyped directly but is flanked by genetic markers that can be genotyped. In these cases, selection of backcross parents is based on marker genotype (Fig. 2). This is referred to as marker-assisted introgression (MAI).

Most studies have considered MAI of single QTL (4,5) but often several QTL must be introgressed simultaneously. Several studies (1) have shown that large population sizes are needed to obtain sufficient individuals that are heterozygous for all QTL in the backcrossing phase. This would make MAI not feasible in livestock breeding programs.

In many cases, however, immediate fixation of introgressed QTL alleles may not be required. Instead, the objective of the backcrossing phase can be to enrich the recipient breed with the favorable donor QTL alleles at high enough frequency such that they can be selected on following backcrossing. Consequently, the objective of this study was to evaluate the efficiency of MAI of multiple QTL in a backcross program of limited size. The impact of selected proportion, size of introgressed regions, and number of QTL were considered.

Materials and methods

The F1 and five backcross (BC) generations from a cross between two inbred lines that were fixed for alternate alleles at QTL and at pairs of flanking markers (Fig. 2) were simulated. One, three, or five unlinked QTL were simulated at the center of marker intervals of 0, 5, or 20 cM. A total of 500 BC progeny were generated each generation by mating 2, 5, 10, or 20% of BC individuals to the recipient parental line. The BC progeny were selected on the expected number of donor alleles at the n introgressed QTL, as determined from marker genotypes: $I = \sum_i^n P(Q_i)$, where $P(Q_i)$ is the probability that

the individual carries the donor allele for QTL i . Probabilities $P(Q_i)$ were set equal to 1, $\frac{1}{2}$, and 0 if the individual carried two, one, and zero donor alleles at the two markers that flanked the QTL, ignoring double recombinants. Efficiency of MAI was evaluated by the frequency of donor QTL alleles, averaged over loci.

Results

Table 1 shows the average and standard deviation of QTL frequencies for five backcross generations with introgression of three QTL. Results were based on 100 replicates and

averaged over the three QTL. The ability to maintain a frequency of 50% for the donor QTL alleles depended on the fraction selected and marker distance. With a selected fraction of 2 or 5%, sufficient BC individuals could be identified that were heterozygous at all flanking markers and reductions in frequencies from 50% were the result of double recombinants. Because double recombinants are more frequent with larger marker intervals, a slight reduction in frequency was observed for the 20 cM interval. This was also the case for 10% selected when marker intervals were 0 and 5 cM, but for a 20 cM interval with 10% selected and for all intervals with 20% selected, some selected individuals were not heterozygous for all flanking markers. The number of such individuals increased with selected proportion and marker interval and resulted in greater reductions in allele frequencies. Nevertheless, even with a 20 cM interval, mean frequencies were 40 and 30% in generation five for 10 and 20% selected, respectively.

Table 2 shows the effect of the number of QTL that are introgressed for 20% selected. As expected, the reduction in frequency over generations increased with number of QTL and marker distance. Introgression of five QTL resulted in a mean frequency of 21% in generation five. Reductions would be smaller for greater selection intensities.

Discussion and Conclusions

Results presented here show that, although it may not be possible to maintain a frequency of 50% during backcrossing in populations of limited size, MAI can introduce multiple QTL alleles at frequencies that will enable their selection following backcrossing.

In this study, five generations of backcrossing were used and selection was on the QTL alone. Ultimately, the optimal selection strategy, including the number of generations of backcrossing, must be based on an economic analysis that involves the effects of the QTL, the difference in background genome effects, the opportunity cost of potential selection response that is lost for other genes, and the costs that are associated with an introgression program.

Acknowledgments

This work was funded by USDA/CSREES IFAFS grant # 00-52100-9610.

References

1. Koudandé, O.D., Iraqi, F., Thomson, P.C., Teale, A.J. and van Arendonk J.A.M. (2000) *Mamm Genome*. **11**: 145-50.
2. Malek, M., Dekkers, J.C.M., Lee, H.K., Baas, T.J. and Rothschild, M.F. (2001a) *Mamm Genome*. **12**: 630-36.
3. Malek M., Dekkers, J.C.M., Lee, H.K., Baas, T.J., Prusa, K., Huff-Lonergan, E. and Rothschild, M.F. (2001b) *Mamm Genome*. **12**: 637-45.
4. Visscher, P.M., C.S. Haley and R. Thompson (1996). "Marker-assisted introgression in backcross breeding programs." *Genetics* **144**: 1923-32.
5. Yancovich, A., Levin, I., Cahaner A. and Hillel, J. (1996) *Anim Genet*. **27**: 149-55.

Table 1. Average and standard deviation of QTL frequencies in five backcross generations for various selected proportions and marker interval distances for introgression of three unlinked QTL. Results are based on 100 replicates.

% Selected	Marker interval (cM)	QTL frequency in backcross generation				
		1	2	3	4	5
2	0	0.50 ± 0.00	0.50 ± 0.00	0.50 ± 0.00	0.50 ± 0.00	0.50 ± 0.00
	5	0.50 ± 0.00	0.50 ± 0.00	0.50 ± 0.00	0.50 ± 0.00	0.50 ± 0.01
	20	0.50 ± 0.02	0.49 ± 0.03	0.49 ± 0.06 ^a	0.48 ± 0.07 ^a	0.48 ± 0.7 ^a
5	0	0.50 ± 0.00	0.50 ± 0.00	0.50 ± 0.00	0.50 ± 0.00	0.50 ± 0.00
	5	0.50 ± 0.00	0.50 ± 0.00	0.50 ± 0.00	0.50 ± 0.00	0.50 ± 0.01
	20	0.50 ± 0.01	0.49 ± 0.02	0.49 ± 0.02	0.49 ± 0.03	0.48 ± 0.04
10	0	0.50 ± 0.00	0.50 ± 0.00	0.50 ± 0.00	0.50 ± 0.00	0.50 ± 0.00
	5	0.50 ± 0.01	0.50 ± 0.01	0.50 ± 0.01	0.50 ± 0.01	0.50 ± 0.01
	20	0.48 ± 0.02	0.46 ± 0.03	0.43 ± 0.03	0.42 ± 0.04	0.40 ± 0.04
20	0	0.44 ± 0.02	0.40 ± 0.02	0.37 ± 0.02	0.36 ± 0.03	0.35 ± 0.03
	5	0.44 ± 0.02	0.40 ± 0.03	0.37 ± 0.03	0.36 ± 0.03	0.35 ± 0.04
	20	0.43 ± 0.02	0.38 ± 0.02	0.35 ± 0.03	0.32 ± 0.03	0.30 ± 0.04

^a The standard deviation is increased because one QTL was lost in one replicate.

Table 2. Average and standard deviation of QTL frequencies in five backcross generations with introgression of one, three, or five unlinked QTL for different marker intervals and 20% selected. Results are based on 100 replicates.

Number of QTL	Marker interval (cM)	QTL frequency in backcross generation				
		1	2	3	4	5
1	0	0.50 ± 0.00	0.50 ± 0.00	0.50 ± 0.00	0.50 ± 0.00	0.50 ± 0.00
	5	0.50 ± 0.00	0.50 ± 0.00	0.50 ± 0.01	0.50 ± 0.00	0.50 ± 0.01
	20	0.50 ± 0.01	0.49 ± 0.01	0.48 ± 0.02	0.48 ± 0.03	0.47 ± 0.05
3	0	0.44 ± 0.02	0.40 ± 0.02	0.37 ± 0.02	0.36 ± 0.03	0.35 ± 0.03
	5	0.44 ± 0.02	0.40 ± 0.03	0.37 ± 0.03	0.36 ± 0.03	0.35 ± 0.04
	20	0.43 ± 0.02	0.38 ± 0.02	0.35 ± 0.03	0.32 ± 0.03	0.30 ± 0.04
5	0	0.41 ± 0.02	0.34 ± 0.03	0.31 ± 0.03	0.28 ± 0.04	0.25 ± 0.04
	5	0.41 ± 0.02	0.34 ± 0.03	0.30 ± 0.03	0.27 ± 0.04	0.24 ± 0.04
	20	0.39 ± 0.02	0.32 ± 0.03	0.27 ± 0.03	0.23 ± 0.04	0.21 ± 0.04

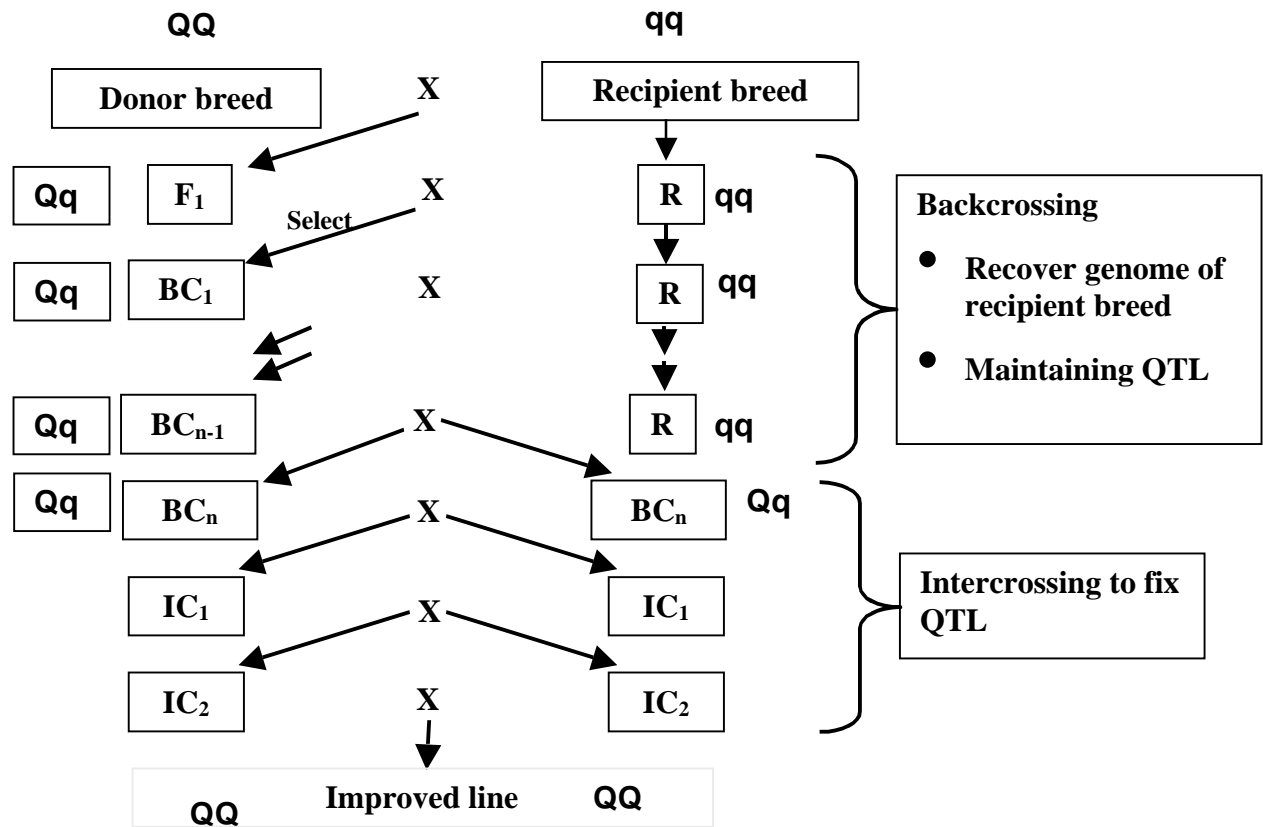

Figure 1. Two successive phases of introgressing a QTL from a donor breed (QQ genotype at QTL) into a recipient breed (qq genotype): a backcrossing phase and an interbreeding phase.

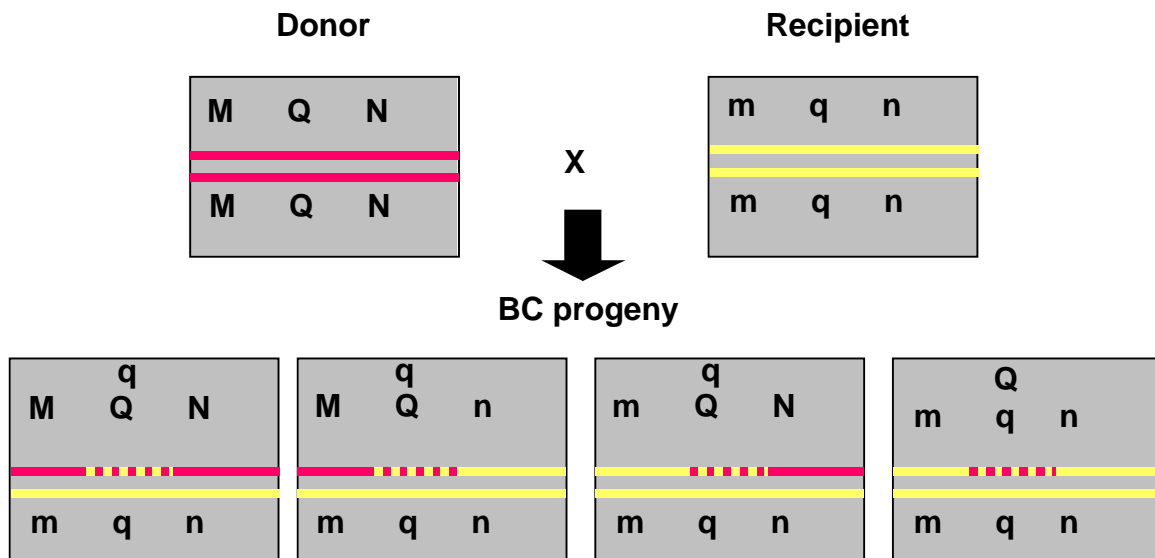

Figure 2. The inheritance of QTL and flanking markers in the backcross progeny. All backcross progeny receive one (intact) chromosome from the recipient breed and one chromosome from the BC parent. The BC chromosomes can be recombined and contain zero, one, or two marker donor alleles at flanking markers. MN chromosomes likely also contain the donor QTL allele (Q), apart from double recombination, and are the ones that are ideally selected.