

Journal of

INDUSTRIAL TECHNOLOGY

Volume 23, Number 2 - April 2007 through June 2007

Martempering to Improve Wear Properties of Aircraft Brake Steel Rotors

By Dr. Sudershan Jetley

Peer-Refereed Article

KEYWORD SEARCH

***Aviation Technology
Materials & Processes
Materials Testing
Metals
Quality Control
Research***

The Official Electronic Publication of the National Association of Industrial Technology • www.nait.org

© 2007



Dr. Sudershan Jetley is an associate professor at College of Technology in Bowling Green State University. He received his Ph.D. from University of Birmingham. He has taught and supervised graduate students in the areas of statics, materials, automation, quality, research methods and manufacturing processes. His research interests include Rapid Prototyping, Machining, Neural Network applications and Machine vision.

Martempering to Improve Wear Properties of Aircraft Brake Steel Rotors

By Dr. Sudershan Jetley

Abstract

This article presents a study to improve the wear properties of aviation brake rotors. Currently these rotors are being austempered using a hot salt bath. This has caused safety concerns in the plant, so an alternative martempering process was investigated using oil and water based quenchants at lower temperature. The test samples were evaluated for hardness, distortion and wear under accelerated simulated tests. The results show that although both hardness and wear resistance was lower compared to the austempering, it met the design intent. Also the wear rate of martempered samples was more consistent which may provide advantages for maintenance purposes.

Introduction

The wheel has evolved from a simple wooden disk of antiquity to the sophisticated composite structure of today used in land and air vehicles. This evolution has been the result of meeting the challenge of ever increasing higher speeds and loads. A vital component of the composite wheel is its brakes. The primary requirement of modern brake systems is to be able to apply a braking torque while resisting failure due to high friction temperatures developed. This is reflected in national and international regulations for certification.

For aircraft, Federal Aviation Regulation, Code of Federal Regulation Part 23 and the United Kingdom Civil Authority Specification No. 17 specify the required energy capacity rating for Brakes. The specifications provide the following formula for deriving the Kinetic Energy (K.E.) absorption requirement (United Kingdom Civil Aviation Authority, 2006):

$$K.E. = \frac{-+110WV^2}{N}$$

Similarly Torque (τ), although not specified by the regulating agencies can be derived as:

$$\tau = \frac{0.031WR}{N}$$

Where:

K.E. = Kinetic Energy per wheel in ft.lbs

W = Weight in lbs

V = Speed in Knots

R = Tire Radius in inches

N = Number of wheels

τ = Torque per wheel in inch.lbs

From these relationships, it can be seen that for a given aircraft, speed and weight are the governing factors in brake design. This is again seen in graphical form in figure 1.

Due to the V^2 term in the energy equation, energy effects take on the overriding importance in brake functioning. Consider the scenario of a fully loaded aircraft aborting a takeoff just before the actual takeoff. For a jet fighter, the speed at that moment may be close to 200 miles per hour. There is obviously little reverse thrust to be had from the engines and for a jet fighter there is little aerodynamic drag due to its control surfaces at that moment. The runway is also quickly running out, so the aircraft needs to be stopped quickly. Therefore, all the stopping action falls on the wheel brakes. A commercial jetliner can require in the order of 5,000 braking horsepower per brake (Garret, D.F., 1991).

Figure 1. Effects of Speed and Weight of aircraft on Landing Energy Per wheel (Johnson, 2006)

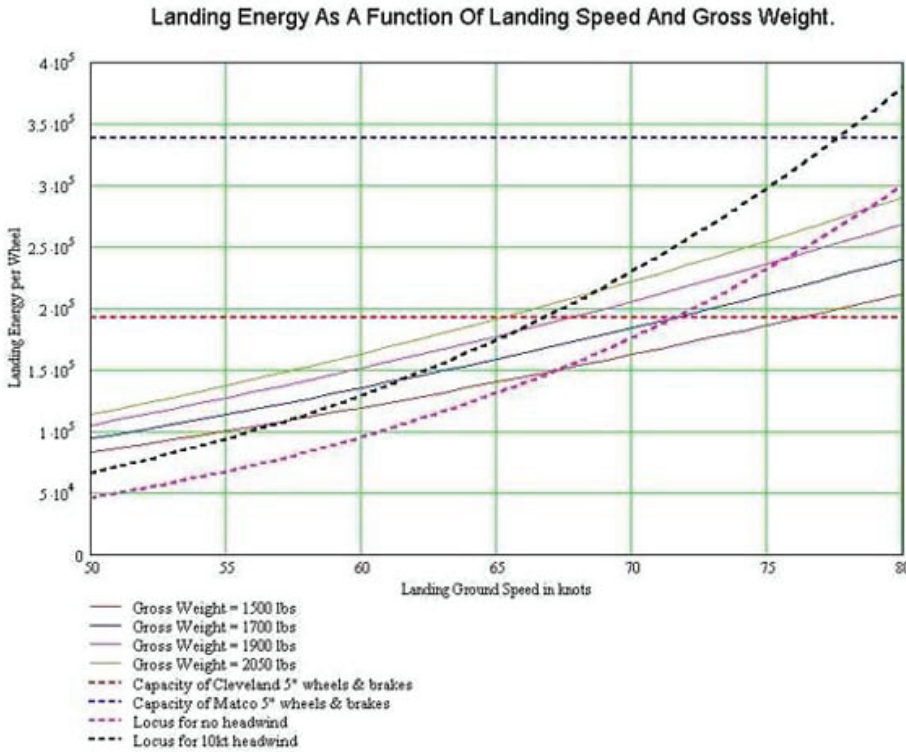

The two essential properties needed are heat dissipation by

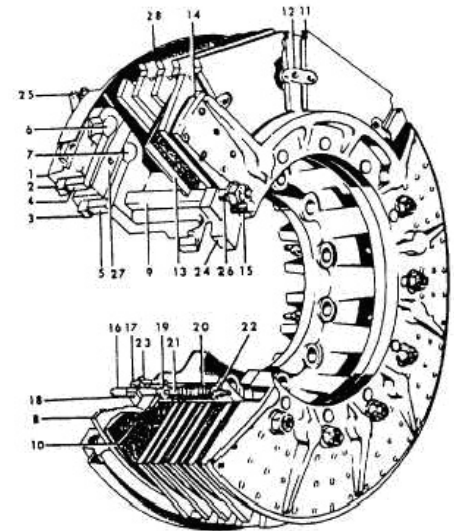

1. Carrier assembly
2. Piston cup (outer)
3. Piston cup (inner)
4. Piston (outer)
5. Piston (inner)
6. Piston end (outer)
7. Piston end (inner)
8. Pressure plate
9. Stator drive sleeve
10. Auxiliary stator and lining assembly
11. Rotor segment
12. Rotor link
13. Stator plate
14. Backing plate
15. Torque pin
16. Adjuster pin
17. Adjuster clamp
18. Adjuster screw
19. Adjuster washer
20. Adjuster return spring
21. Adjuster sleeve
22. Adjuster nut
23. Clamp hold down assembly
24. Shim
25. Bleeder screw
26. Drive sleeve bolt
27. Dust cover (inner)
28. Dust cover (outer)

For a jet fighter at peak speed, the temperatures generated in the brakes due to friction can exceed 2000° F (Hydro Aire Inc., 2005). The situation can be further exacerbated by cross winds that would place additional and uneven loads on the different wheels due to steering compensation needed. At different altitudes, K.E. generated also increases due to increased takeoff or landing speeds required to compensate for increased density altitudes (Johnson, 2006). The heat generated can result in rapid wear of the brake surfaces leading to brake failure, or at the least, reduction in brake life.

Early airplanes had no brakes and relied upon the friction generated from their tails skidding on the grassy ground. When hard runways came into use, aircraft brakes were generally adopted from automobile brakes. These early brakes consisted of drum and shoes systems similar to the rear brakes found in today’s automobiles (Garret, D.F., 1991). The major problem with these types of designs is the thermal expansion

of the fluid and drum leading to loss of brake action. After the World War II, aircraft started to use disc brakes which are used in modern aircraft. There are two types, namely single and multiple disc brakes.

Pre World War II, the landing gear of aircraft was not retracted and stowed. However, with increased speed requirements it became necessary to retract and stow the landing gear to reduce drag. To meet these requirements, wheels became smaller to reduce stow space, leading to the development of multiple disc brakes (Aircraft Technology Engineering and Maintenance, 2000). This design has become standard and all large planes today use the multiple disc brakes. An example diagram of these brake assemblies is shown in figure 2 (Integrated publishing, 2006).

The essential part of the brake assemblies is a rotor rotating in contact against a stationary stator during braking. The industry primarily uses sintered, copper based alloys as stators and steel rotators.

Figure 2. Segmented rotor brake—cut-away view.

the stator and reduced wear rate of both the stator and the rotor. Although the basic design has remained the same over the years, there have been many developments in materials and processing of these materials (Aircraft Technology Engineering and Maintenance, 2000.)

A significant development has been the use of carbon to replace steel since the 1980s. Indeed in some larger aircraft a fully loaded landing and takeoff may not be possible without the utilization of carbon (Graphite) brakes.

However, carbon brakes needs to be thicker than steel brakes due to various reasons such as to provide sufficient volume to act as a heat sink and provide structural strength. Therefore, they require more space due to carbon's lower density, and are also about 1/3 more costly than steel. Therefore, steel rotors, also known in the industry as pucks, remain competitive and are used in most cases (Aircraft Technology Engineering and Maintenance, 2000).

The Project

At an aircraft brake manufacturing facility, the steel rotors (pucks) are heat treated using an austempering process. Austempering is the heat treatment process of heating steel into the austenitic phase, and then quenching to a temperature above the martensitic transformation temperature, which causes the austenite to isothermally transform to bainite. In the process, the quench cycle is interrupted at about 700° F and held for a period at that temperature.

The company uses salt baths to hold the pucks at the constant temperature. The austempered steel met the design expectations of the company, but the process raised concerns regarding safety of workers due to the salt baths used for quenching. Salt bath heat treating is very hazardous, especially during cleaning and in maintaining the baths at elevated temperatures (e-funda engineering fundamentals, 2006). Therefore, a similar but different heat treatment process, martempering, was investigated to provide similar properties but us-

ing safer quenchants. Two quenchants, one oil based and other water based were identified. This article reports this study. (Note: the identity and some of the details of the process are not being provided due to confidentiality requirements)

Martempering is a commonly used heat treatment technique. The purpose of this process is not only to obtain the appropriate microstructures and mechanical properties but also to minimize distortions. In martempering, the part or specimen is heated well into the austenitic region. Once the entire part has reached the specified austenitic temperature it undergoes an interrupted quench at a specified temperature below the Ms temperature of the Time- Temperature – Transformation (TTT) diagram. The part is then slowly cooled through the martensitic transformation. The amount of time the part is kept in the martensitic transformation determines the properties of the part. Once the temperature of the part falls below the Mf line, bainite and very fine pearlite is formed. The last step in the martempering process is to temper the part at the specified temperature for the specified amount of time. This relieves stresses produced due to quenching and converts any retained austenite to pearlite, thus reducing the possibility of spontaneous transformations that can lead to cracking (e-funda engineering fundamentals, 2006.)

In summary, the purpose of this study is to assess the feasibility of martempering heat treatment using two different quenchants. This is to replace the current Austempering heat treatment being used on Aircraft Brake Steel Rotors. The results of martempering are assessed using hardness, distortion and friction testing. The main impetus for this study comes from the need to avoid the use of salt baths.

Methodology

Apparatus

1. Hardness Testing Machine
Wilson Rockwell Hardness Tester machine was used to measure hardness.

This is shown in figure 3. The Hardness machine can be used with several different scales including Rockwell A-G, H, and K. In this study Rockwell scales B and C were used.



Figure 3. Rockwell Hardness Tester

2. Small Electric Furnace

A small electric oven was used to temper the pucks after they had been quenched. The oven is made by Hevi Duty Electric Co. model number MU-56-S. The oven has a voltage range of 110-200, a maximum wattage is 3400, and a temperature range of 0° to 1200° F.

3. Large Electric Furnace

An electric oven was used to austenize the pucks before they were placed into the quenchant. Figure 4 is a photo of the furnace. The large furnace is made by Therolyne, and model number F-A1730. The furnace has a temperature range of 0° to 2500° F.

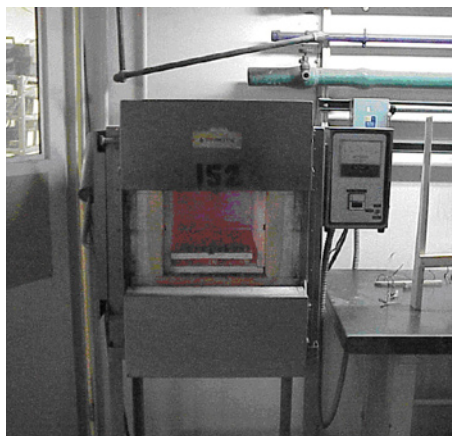

Figure 4. Large Electric Furnace

4. Height Gage

North American Precision Inc. height gage was used to measure the thicknesses at eight different points on the puck. Three measurements at each position were taken to obtain the thickness. Figure 5 shows a close-up view of the gage.

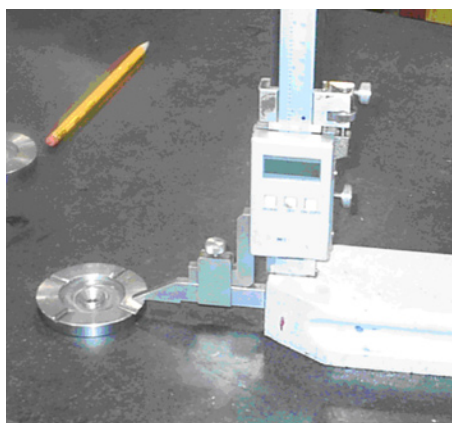

Figure 5. Height Gage / Thickness Measuring

5. Cooling Rack

A beaker stand was used as the holding device for the pucks after treatment. The pucks were hung using wire coat hangers bent into a shape to hold them flat while entering the hot quenchant. This presented the maximum surface area during initial contact with the fluid, and so should cause maximum distortion. The coat hanger surface touching the pucks was minimized to avoid uneven cooling. Figure 6 shows this set-up.

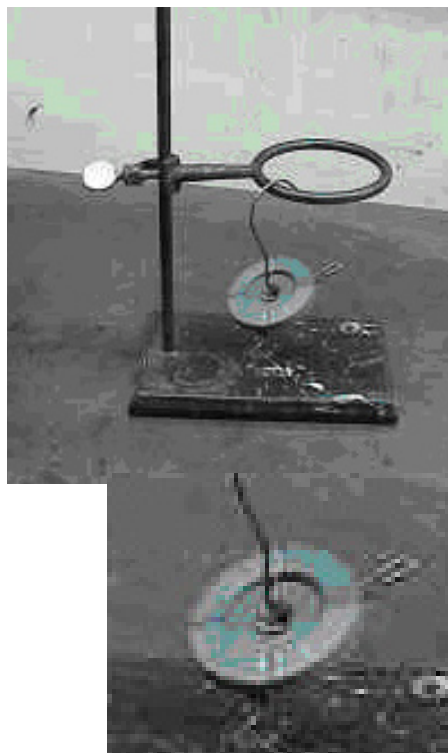

Figure 6. Beaker/Hanger set up and a close-up view

6. Quenchant Pot

An electric pot with a temperature setting control was used to quench the pucks. The electric pot is a domestic kitchen pot and has a half gallon holding capacity. The temperature range on the pot is 0° to 400° F. The temperature control was used to set the quenchant temperature and a ‘Suregrip’ thermocouple temperature probe was used to actually monitor the quenchant temperature. This probe has a temperature range of -40°F to 1994° F. Figure 7 is a photo of the electric pot.



Figure 7. Electric Pot

Materials

1. Steel Parts

As mentioned above, the part under investigation was the steel puck which forms the rotor part of a brake assembly. It can be seen in figures 5 and 6. The part is approximately 2.5 inches in diameter and 0.33 inch thick. It was received in annealed and machined condition. It was made with the standard 17 – 22 – A Timken steel. The composition of the steel, in percentages, is given in Table 1 (see page 6), as provided by the manufacturer.

2. Quenchants

The aqueous quenchant used was the Aqua Quench 3699 from Houghton International Inc. (<http://www.houghtonintl.com/index.html>). It was used at a concentration of 25% water solution, based on manufacturer’s recommendation. It is a polymer based liquid and has some of the properties as shown in table 2 (see page 6) as provided by the manufacturer. The oil based quenchant, also supplied by Houghton International Inc., was mart-temp oil 2525. It is based on paraffinic mineral oils with additives. This was used at 100% concentration. Some of its properties are shown in table 3 (see page 6) as provided by the manufacturer.

Procedures

1. Puck Identification

In order to identify the different pucks, these were stamped with an identifying letter (A to T). In order to be consistent in the various measurements, these were labeled so that the measurement was done at approximately the same place and orientation. The labels consisted of stamped letters N, S, E, W, at two places, in the four directions so their orientation could be quickly found as shown figure 8.

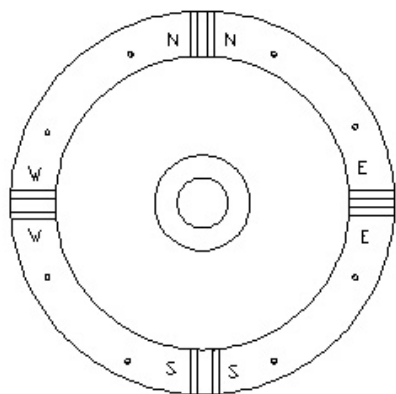

Figure 8: Labeled positions on a steel puck

2. Dimensional measurements

In order to assess any distortion that may occur during heat treatment, ideally profiles of the parts should be taken by such a device as a coordinate measuring machine. However due to lack of appropriate apparatus, thickness (or height) and roundness of the parts were measured. Height was measured by placing the disc on a surface plate and using the digital height gage at the four different labeled points, taking two readings at each point, resulting in eight readings per part.

The heights were recorded before and after the pucks were heat treated to see if there was any distortion in the axial direction after treatment. The pucks were thoroughly cleaned using sandpaper to remove any scale for the after heat treatment measurements. The set-up is shown in figure 5.

To assess any distortion in the radial direction, each puck was traced on a sheet of graph paper, and then retraced after it had been heat treated and tempered. Transparencies of the after heat treatment traces were overlaid on the traces of the before heat treatment traces to evaluate any differences. Parts labeled K, P, E and R were used for oil quenching and those labeled Q, M and T for aqua quenching.

3. Hardness measurements

Hardness was measured three different times during experimentation. First time hardness was measured before any heat

Table 1. Chemical composition of “17-22-A” S Timken Steel (AMS spec; 6302 B)

C	Mn	P	Si	S	Cr	Mo	V
.28-.33	.45-.65	.040	.55-.75	.04	1.0-1.5	.40-.60	.2-.3

(http://www.timken.com/timken_ols/mail/contact.asp)

Table 2. Properties of Aqua-quench 3699

Appearance	Hazy Light Amber Fluid
Viscosity at 100° F	687 ± 25 cSt
Specific Gravity at 60° F	1.025
Density at 60° F	8.5 lb/gallon
pH	9.3 ± 0.5
Corrosion Protection	Excellent
Water solubility	Normal

Table 3. Properties of mart temp oil 2525

Viscosity	@ 100° F	567 c St.
	@ 210° F	33 c St.
Flash point		550° F
Fire Point		620° F
Specific Gravity @ 60° F		0.892

treatment had been conducted. Since, the pucks received were in an annealed state, the hardness was measured using the HRb scale.

The second and third time the hardness was taken after quenching and tempering respectively. This was done with a HRC scale. In both cases, pucks were cleaned thoroughly to assure accurate hardness data. In all cases, the average of the two harnesses was used and hardness measurements were taken left of the stamped letter N and at right of the stamped letter S on the pucks.

4. Heat treatment

The austenizing temperature used in the oven was 1650° F in air. For quenching, the oil based quenchant was used at 400° F and the water based at 150° F. These temperatures were recommended by the manufacturer. The pucks were quenched for 30 seconds. As shown in fig.6, the orientation of the pucks when inserted into the quenchant was horizontal as this orientation should produce maximum

distortion if any. In actual production, the pucks should be inserted in a vertical orientation to minimize the distortion, which then would be less than observed in this study. As stated earlier under the quenching pot description section, the rise in quenchant temperature was also monitored during quenching using the temperature probe.

After quenching, the parts were tempered at 1200° F for one hour. This was done in the oven and then air cooling on the bench.

5. Friction testing

After the parts were heat treated they were tested by accelerated sub scale friction testing. This test simulates the braking loads experienced by an aircraft. Multiple cycles of braking were simulated. Briefly, a rotor (The puck) is pressed against a stator, which is a Cu-Fe-C-Si powder metal flat plate. The tests allow the control of rotational speed, pressure etc. These are based on the Cold Taxi Stop, Service Landing and Hot Taxi

Snub conditions. A test cycle consists of all these braking conditions. The test yields such data as coefficient of friction, temperature generated, energy used, wear loss and the like.

Results and Discussion

Distortion in axial direction

This distortion was assessed by measuring the heights of the pucks before and after hardening against a surface plate at the eight positions. The total range of all measurements was 8.9 to 8.1 mm.

The results are shown in tables 4, 5 and 6. The difference column in table 5 is the difference in average values, with corresponding standard deviation of the difference. “n” denotes the number of readings.

There seem to be a reduction in thickness after hardening in both quenchant; 0.032 mm for the aqueous quenchant and 0.105 mm for the oil quenchant as seen in table 5. This is confirmed in table 6, which shows that statistically the probability of there being zero difference in the before and after heat treatment for all pucks is quite small, with sample size of 8, i.e. n = 8. So the reduction in thickness is due to some assignable causes.

This may be due to scale that had built-up and subsequent cleaning before measuring. Oxidation was found on all parts. The standard deviations of the means before and after hardening are almost the same. If there had been any significant distortion, the difference values and their standard deviations in table 5 would have increased, rather than decreased. Similarly the maximum values would also have increased, due to the method of measuring, which is not observed. So we can state that there was little to no distortion due to quenching in the axial direction and the differences observed in height values could be due to causes such as oxidation and cleaning. This can be investigated in some future work.

Furthermore the parts were oriented to present maximum surface area to the liquid, to cause maximum distortion. In practice this would not be the case, since

Table 4. Height (thickness) measurements of individual pucks

	Heights (mm) Oil quenchant			Heights (mm) Aqua quenchant	
	Before hardening	After hardening		Before hardening	After hardening
E			M		
Maximum	8.455	8.9	Maximum	8.47	8.36
Minimum	8.4	8.36	Minimum	8.42	8.32
Difference	0.055	0.54	Difference	0.05	0.04
K			Q		
Maximum	8.46	8.39	Maximum	8.46	8.35
Minimum	8.42	8.36	Minimum	8.41	8.31
Difference	0.04	0.03	Difference	0.05	0.04
P			T		
Maximum	8.44	8.43	Maximum	8.5	8.37
Minimum	8.42	8.14	Minimum	8.415	8.31
Difference	0.02	0.29	Difference	0.085	0.06
R					
Maximum	8.455	8.44			
Minimum	8.415	8.405			
Difference	0.04	0.035			

Table 5. Height (thickness) measurements overall

	Height (mm)	Oil (E, K, P & R)	Difference	Height (mm)	Aqua (M, Q, T)	Difference
	Before Hardening	After Hardening		Before Hardening	After Hardening	
n	32	32		24	24	
Average	8.434	8.042	-0.032	8.44	8.34	-0.105
Std. Dev.	0.015	0.014	-0.001	0.022	0.018	-0.004

Table 6. Student’s t and probability values, assuming nulls hypothesis, for height measurements of all pucks before and after heat treatment (n=8)

	Oil quenchant					Aqua quenchant		
	E	K	P	R		M	Q	T
t	6.86	10.1	2.94	2.88		13.6	13.1	7.6
P	0.001	0.001	0.011	0.012		0.0001	0.0001	0.0001

P = Probability of no difference in height values before and after heat treatment hypothesis

pucks would be orientated to reduce the initial contact surface.

Distortion in radial direction

Although radial distortion is not of much importance in the functioning of the pucks, an attempt was made to measure this. As has been stated, the ideal method for measuring radial distortion would have been to use a profilometer or a CMM. In absence of such apparatus the above described tracing method was used. In all the eight parts used, no radial distortion was detected. An estimate of the accuracy of this method can be obtained as follows:

The visual error in the procedure of comparing the two tracings can be said to be half of the pencil line width, so it is in the order of 0.5 mm. Since the diameter of the puck was about 65 mm, the measurement error translates to 1.54 %. (1mm/65mm * 100 = 1.54). An example of the tracing is shown in figure 9.

Hardness

The hardness results are shown in table 7 and 8. Each value is an average of two readings. The initial low hardness was due to the annealed condition of the pucks. The hardness value increased in both cases due to martensitic transformation. The temperature differences between the hot part out of the oven and the pre heated quenchants were 1250° F (1650 – 400 = 1250) and 1500° F (1650 – 150 = 1500) for the oil and water based quenchants respectively. Water generally has 2 to 3 times greater thermal conductivity as well as heat capacity than oils (Wikipedia, 2006) (Huksflux, 2006).

Hence, these two factors should have cooled the aqua quenched parts faster than the oil quenched parts. This was also seen by the fact that the oil based quenchant temperature rose by 20° F and the Aqua Quench 3699 water based polymer quenchant by 35° F. The small decrease in hardness after tempering was as expected, which is mainly due to stress relief.

This decrease is greater with water based quenchant, indicating that more quenching stresses were produced and

Figure 9. Example of a tracing to determine radial distortion

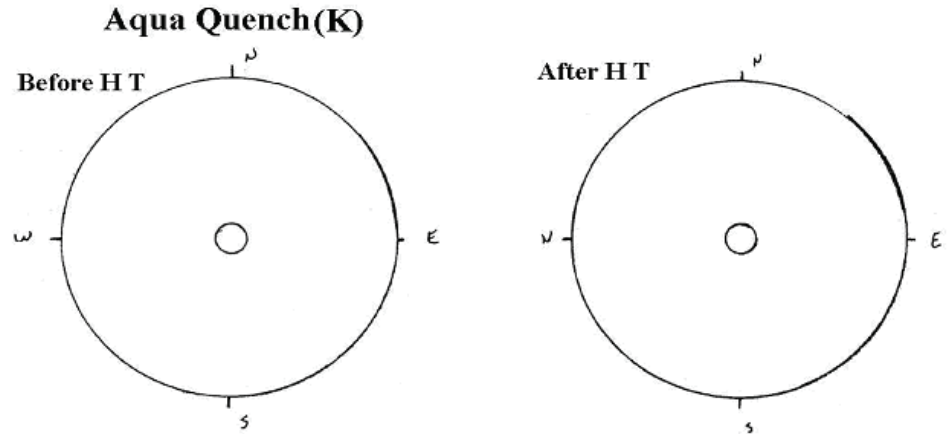

Table 7. Hardness values of oil quenched parts

	Puck# R	Puck# P	Puck# E	Puck# K	Average	Std. Dev.
Initial (HRb)	8	9	8	8	8.25	0.433
After Quenching (HRc)	24	23	27	26	25	1.58
After Tempering (HRc)	22	23	26	26	24.25	1.79

Table 8. Hardness values of Aqua quenched parts

	Puck# T	Puck# M	Puck# Q	Average	Std. Dev.
Initial (HRb)	8	8.5	9	8.5	0.5
After Quenching (HRc)	38	37	39	38	1
After Tempering (HRc)	31	30	33	31.33	1.53

Table 9. Results of the friction tests.

Part Number	Rotor Wear Rate	Stator Wear Rate	Brake Wear Rate	Hardness
(Aqueous)	Inches/cycle	Inches/cycle	Inches/cycle	HRb
T	0.0325	0.0359	0.0684	31
Q	0.0283	0.0391	0.0674	33
M	0.0282	0.0403	0.0685	30
Average	0.029667	0.038433	0.0681	31.33333
Standard Deviation	0.002454	0.002274	0.000608	
(Oil)				
P	0.0274	0.0351	0.0598	23
R	0.03	0.0303	0.0603	22
K	0.0213	0.0392	0.0605	26
Average	0.02685	0.0336	0.059775	23.66667
Standard Deviation	0.004466	0.004455	0.000361	

there may have been more retained austenite, which is again to be expected due to greater cooling rate. This can be confirmed further through metallographic analysis which would be focus of further study.

Friction tests

The results show that the temperatures generated, energy used and the wear loss were in the order of magnitude higher for service landing portion of the cycles than other portions. Due to the propriety nature of the results, a brief summary of the results is provided in table 9. These results show that stators wear at a greater rate than rotors in general.

The probability of this not being true is about 1 and 7.7 percent for the water and oil based quenched rotors respectively as shown in table 10. Similarly the wear rate of rotors is less than that of stators when aqueous quenched rotors are used compared to the oil quenched rotors. The probability of this not being the case is greater as indicated in table 11.

Based on the results, the company reported that, when compared with martempering, the current austempering process yields much greater hardness values and a lower rotor wear rate. However the stator wear rate is significantly greater, i.e. there is a larger difference in the wear rates between stator and rotor with current austempering process compared to martempering process of this study.

The element with the lowest melting point in the whole brake system is copper with a melting point of 1981° F, which is the main component of the stators’ composition. Although this temperature may be significantly reduced due to alloying. The temperatures generated during the friction test ranged from about 100 to 500° F for time periods ranging from 1.5 to 25 seconds. These conditions do not appear to be conducive to cause diffusion wear. Therefore, it is most likely that the wear is governed by adhesion and abrasive wear mechanisms causing the harder rotor to wear less than the softer stator.

Table 10. Student’s t and probability values, assuming nulls hypothesis, for wear rates difference between stators and rotors used in aqueous and oil quenchants (n= 3)

	t	P
Aqueous	4.54	0.011
Oil based	2.37	.077

P = Probability of no difference in wear rates between rotors and stators for the two quenchants. (n= 3)

Table 11. Student’s t and probability values, assuming null’s hypothesis, for wear rates difference between aqueous and oil quenchants for stators and rotors (n= 3)

	t	P
Stators	1.24	0.28
Rotors	1.17	0.31

P = Probability of no difference in wear rates between rotors and stators for the two quenchants. (n= 3)

Based on the limited experimental tests, we can speculate that when there is a greater difference in the hardness between the stator and the rotor, the abrasion wear mechanism predominates. When the hardness difference is reduced, the adhesion mechanism starts to predominate. This can be tested in the future by metallographic analysis.

Regarding the total brake wear, the results show that there was less variation in wear rate with the martempering processes when compared to the austempering process as reported by the company. This is useful from brake maintenance and stator and rotor utilization view points, since it may lead to more effective maintenance schedules.

Conclusions and comments

1. The martempering did not produce any significant distortion, axial or longitudinal.
2. The mart-temp oil 2525 yielded lower hardness than the Aqua Quench 3699 quenchant.
3. The wear rate in the friction test was lower for the rotors that were austempered in the current process than the martempered rotors

4. The wear rate in the friction test was higher for the stators that used austempered rotors than the martempered rotors
5. The variation in wear rate for the brake assembly in the friction test was higher for the tests that used austempered rotors than the martempered rotors. Therefore, the martempering process will be more beneficial from maintenance viewpoint.
6. Due to the lower quenchant temperature and less hazardous nature of the Aqua Quench 3699 quenchant compared to salt baths, martempering process based on this quenchant is likely to be much safer and less costly than the current salt bath based austempering process.
7. Additional friction tests and further micro structural and wear analysis work should be conducted to better understand the wear behavior during the friction tests.

References

Aircraft Technology Engineering and Maintenance, (2000). *Stopping at all costs*, Aircraft Technology Engineering and Maintenance, Feb/March 2000, www.craneaerospace.com/Solutions/Landing/downloads/braking.

pdf, Available: 7/15/06
e-funda engineering fundamentals, (2006). *Tempering*, http://www.efunda.com/processes/heat_treat/softening/tempering.cfm, Available: 7/15/06
Garret, D.F., Aircraft Systems and components, Jeppesen Sanderson, Inc., Englewood, CO, Dec. 1991.
Hukseflux Thermal Sensors, (2006). <http://www.hukseflux.com/thermal%20conductivity/thermal.htm>, Available: 7/15/06
Hydro Aire Inc, (2005). *How Brake control Can Prolong the Life of Carbon Brakes*, pp 1-4, <http://www.hydroaire.com/downloads/Brake-Savings.pdf>, Available: 10/4/05

[hydroaire.com/downloads/Brake-Savings.pdf](http://www.hydroaire.com/downloads/Brake-Savings.pdf), Available: 10/4/05
Integrated publishing, (2006). <http://www.tpub.com/air/12-26.htm>, Available: 7/15/06
Johnson, P., (2006)., *Kinda Kozy MKIV RG SVX (C – GPLE)*, <http://www.canardzone.com/members/PhillipJohnson/General/brakes.htm>
Available: 7/15/06
United Kingdom Civil Aviation Authority, *Specifications and tests*, Specification No. 17, 1, ISBN 1 904862 78 0, Sept. 1986, <http://www.caa.co.uk/docs/33/CASPEC17.PDF>, Available: 7/15/06

Wikipedia (2006). *Specific Heat Capacity*, http://en.wikipedia.org/wiki/Specific_heat_capacity, Available: 7/15/06

Acknowledgements

The author thanks Messrs. Jason Grubb and Brad Cymbola for most of the experimental work done; the brake manufacturers for providing the test specimens and conducting wear tests; Houghton International for providing the quenchant; and the College of Technology, BGSU for providing the equipment and facilities to conduct the work.

