

# Design and Construction of Illinois's First Precast Deck Panel Bridge with UHPC Joints

David Liu, PhD, SE, PE, TranSystems

Jayne Schiff, SE, PE, Illinois Department of Transportation

## Abstract:

A new bridge deck system developed a few years ago using Precast Deck Panels with Ultra High Performance Concrete (UHPC) joints has been gaining popularity. This new deck system utilizes the superior characteristics of UHPC to simplify the precast panel fabrication and installation processes as opposed to the conventional approach such as internal post-tensioning. This paper presents the application of this new deck system to a recent \$450 million Circle Interchange Project in Chicago.

**Keywords:** Accelerated Bridge Construction, ABC, Precast Deck Panel, UHPC

## 1. Introduction

Accelerated Bridge Construction (ABC) using prefabricated bridge components and systems has many advantages over conventional cast-in-place construction. Prefabrication speeds up construction and increases the quality of concrete members by fabricating in a controlled plant environment with reduced dependency on the weather. Prefabrication also increases construction safety by avoiding forming, rebar placement, concrete placement and curing at the bridge sites. The reduction in the duration of traffic closures and a reduced negative impact on the environmental are other benefits for using ABC.

Utilizing the superior characteristics of UHPC enables the simplification of the precast panel fabrication and the installation process. This simplified design provides the owner with improved tolerances, reduced risk, and increased speed of construction. It also provides an overall cost savings in construction in some cases and a more durable, longer lasting bridge deck solution.

As a part of the \$450 million Circle Interchange Project, the existing Peoria Street Bridge over I-290 and the Chicago Transit Authority (CTA) was replaced with a 3-span, continuous, steel plate girder bridge with a total length of 273'-0" and a bridge width of 56'-4". Three alternatives were proposed to the Illinois Department of Transportation (IDOT) for consideration: 1) Precast deck panels with internal post-tensioning; 2) AccelBridge System; and 3) Precast deck panels with UHPC joints. The Illinois Department of Transportation decided to select the new generation deck system: precast deck panels with UHPC joints because UHPC is a material and new technology.

In this paper, the three approaches to provide the continuity between the precast deck panels are reviewed. The design procedure for precast deck panels with UHPC joints and UHPC joint details are presented. Construction costs between Cast-In-Place (CIP) concrete deck and

precast deck panels with UHPC joints are compared. Lessons learned from design and construction are discussed in this paper.

## 2. Precast Deck Panels, UHPC and UHPC Joints

One of the largest and specific challenges facing bridge owners is the long-term durability of bridge decks which receive continuous impact loading from trucks and changing environmental conditions, especially the use of salts and de-icing chemicals in cold regions. The years of continuous flexural and thermal stresses create long-term deterioration and maintenance issues for bridge decks. While CIP concrete decks and corrosion resistant reinforcing steel such as epoxy coated rebar could extend the decks life, it creates high user inconvenience and is problematic for bridge deck replacement in high traffic areas. The use of precast deck panels is a common method to speed construction and address the user's inconvenience.

Full-depth precast panel systems have many other advantages over CIP decks, some of the advantages include shorter construction times, high-quality plant production under tight tolerances, low permeability, less variation in volume caused by shrinkage and temperature changes during initial curing, and lower maintenance costs.

The use of full-depth precast concrete deck panels in highway bridges in the United States started as early as 1965 (Badie and Tadros 2008). In 2001 the Federal Highway Administration (FHWA) launched a new initiative called Accelerated Bridge Construction (ABC). As of 2011, more than 60 projects using precast deck panels have been successfully completed (Badie and Tadros 2011).

Illinois built its first precast deck panel bridge on Illinois Route 29 over Sugar Creek, in 2000. This was a deck replacement project. The precast deck panels were full depth, 195mm (7.68") thick and were post-tensioned longitudinally. A 60mm (2.36") Microsilica Concrete Overlay was placed on top of the panels. The deck has performed well. The latest NBIS inspection rates the deck as an 8, very good condition and no problems are noted.

Research and experience indicate that the most critical location in a full-depth precast deck system is the transverse joint between panels. Transverse joints are subject to shear and to tensile stresses in the longitudinal direction. The integrity of transverse joints is essential for structural performance and durability.

There are three approaches to provide the continuity between precast deck panels:

- Internal post-tensioning
- AccelBridge system (Jacking and External Post-Tensioning)
- UHPC

The majority of bridges with full-depth precast decks constructed over the last 30 years utilize longitudinal post-tensioning (PT) to ensure long-term joint performance. The use of post-tensioning across the joints has been used as a method to ensure the deck effectively remains structurally monolithic while performing under the constant pounding of truck wheel loads and seasonal conditions, more specifically; to ensure the joint does not deteriorate or leak. While post-tensioning can resolve most of the performance issues, it is not without potential problems. It is expensive, requires specific expertise and equipment for installation, and it has potential for corrosion. Transverse closure pours at abutments and longitudinal closure pours for wider bridges are typically required, which will lengthen bridge deck construction time. Furthermore,

the analysis is complex in terms of the correct post-tensioning forces, creep losses, and grout properties.

AccelBridge system is a patented full depth precast deck system invented by Eddie He. The principle of AccelBridge is to introduce deck longitudinal compression by jacking the deck against the girder. In such a way, the deck can achieve zero-tension without using any post-tensioning (He 2011). As opposed to conventional post-tensioning inside deck panels, AccelBridge system applies external post-tensioning thru the girders to provide the compression in the deck panel joints.

The main advantages of AccelBridge are durability and minimum maintenance. The PT couplers at the grouted transverse joints are the weak link in the typical full depth precast deck system with internal post-tensioning. Any cracking / leaking in the joint will potential cause PT corrosion. AccelBridge provides the needed deck longitudinal compression without PT; thus eliminating any concern of PT corrosion. Also, AccelBridge system uses match cast epoxy joint between panels, which has been proven to be more durable than grouted joints based on the history of segmental bridges (He 2011).

Using reinforced transverse joints with UHPC can achieve joint durability without longitudinal post-tensioning. UHPC joints can replace the time consuming work of coupling PT ducts and installing PT strands.

Ultra High Performance Concrete is a cementitious composite material composed of an optimized gradation of granular constituents, a water-to-cementitious materials ratio less than 0.25, and a high percentage of discontinuous internal fiber reinforcement. The mechanical properties of UHPC include compressive strength greater than 21.7 ksi (150 MPa) and sustained postcracking tensile strength greater than 0.72 ksi (5 MPa). Ultra-high performance concrete has a discontinuous pore structure that reduces liquid ingress, significantly enhancing durability as compared to conventional and high-performance concretes (FHWA 2014).

The research on UHPC started in Europe in the early 90's to explore new possibilities in advanced concrete technologies. At the end of the 90's, ten years of research produced a completely innovative material offering technological performances that had never been seen before. The mechanical and durability properties of UHPC make it an ideal candidate for use in developing new solutions to pressing concerns about highway infrastructure deterioration, repair, and replacement. Since 2000, when UHPC became commercially available in the United States, a series of research projects has demonstrated the capabilities of the material. A handful of state departments of transportation have deployed UHPC components within their infrastructure, and many more are actively considering the use of UHPC (FHWA 2014).

The use of UHPC is being considered in a wide variety of highway infrastructure applications. The high compressive and tensile strengths allow for the redesign and optimization of structural elements. In the United States, UHPC has been used in prestressed concrete girder simple-span bridges, precast concrete deck panels, and field-cast connections between prefabricated bridge components.

In 2009, the first highway bridge using UHPC joints between full-depth deck panels was constructed in the United States. Since then, 17 bridges of its kind have been built in US. As of 2013, there are about six states that have built precast deck panel bridges with UHPC joints.

The UHPC joints are filled with UHPC and reinforcing steel is lapped across the joint. The lap length of reinforcing steel is based on the reference from Design and Construction of Field-Cast UHPC Connections (Graybeal 2014).

Fatigue tests were performed on UHPC joints connecting precast deck panels. Other field-cast UHPC connection tests for the transverse and longitudinal connections between precast deck panels were presented and discussed in FHWA Publication No. FHWA-HRT-11-023 (Graybeal 2010).

Full depth precast deck panels with UHPC joints requires less construction tolerance than precast deck panels with internal post-tensioning because PT ducts have to be lined up precisely at each panel.

### 3. Peoria Street Bridge

As a part of the \$450 million Circle Interchange Project in Chicago, the existing Peoria Street Bridge over I-290 and the CTA was replaced to accommodate the widening of I-290. The new bridge is a 3-span, continuous, galvanized steel plate girder bridge with a total length of 273'-0" and a bridge width of 56'-4". During the preliminary bridge type study, three alternatives were proposed by TranSystems: 1) Precast deck panels with post-tensioning; 2) Precast deck panels with Ultra High Performance Concrete (UHPC) joints; and 3) AccelBridge system ; were proposed to IDOT for consideration. The Illinois Department of Transportation decided to select the new generation deck system: full-depth precast deck panels with UHPC joints.

A plan view of precast deck panel layout is shown in Figure 1. There are 52 deck panels in total and a longitudinal UHPC joint is provided to accommodate the 56-ft wide bridge. Twenty different deck panels are required due to the complex bridge layout such as CTA train station entrance to the west, CTA staircase to the east, and light poles and drainage scuppers. All the transverse and longitudinal joints are filled with UHPC. The shear stud pockets are filled with non-shrink grout.

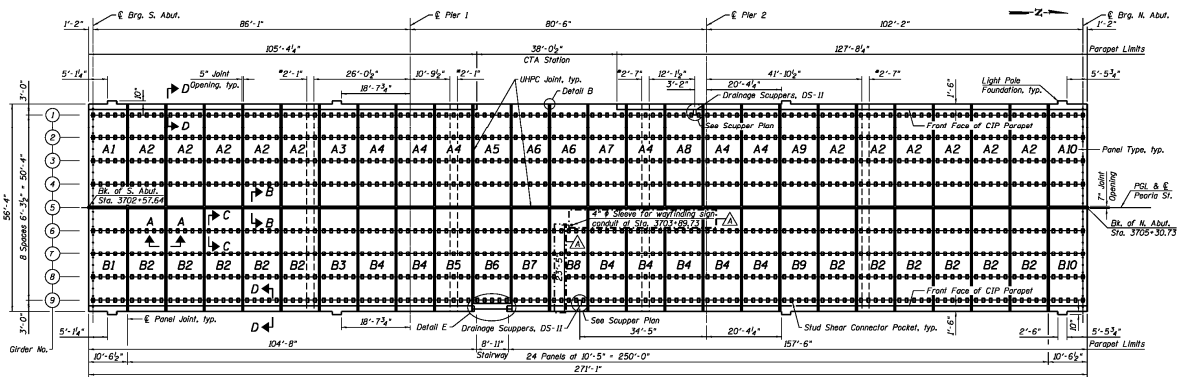

Figure 1. Plan View of Precast Deck Panel Layout

A typical bridge cross section is presented in Figure 2. To reduce future maintenance cost, galvanized steel plate girders were used for this project. Small girder spacing at 6'-3 1/2" was provided to meet the minimum vertical clearance over I-290. A latex concrete overlay with

scored joints was provided on the top of precast deck panels to meet the aesthetic requirement by University of Illinois at Chicago (UIC).

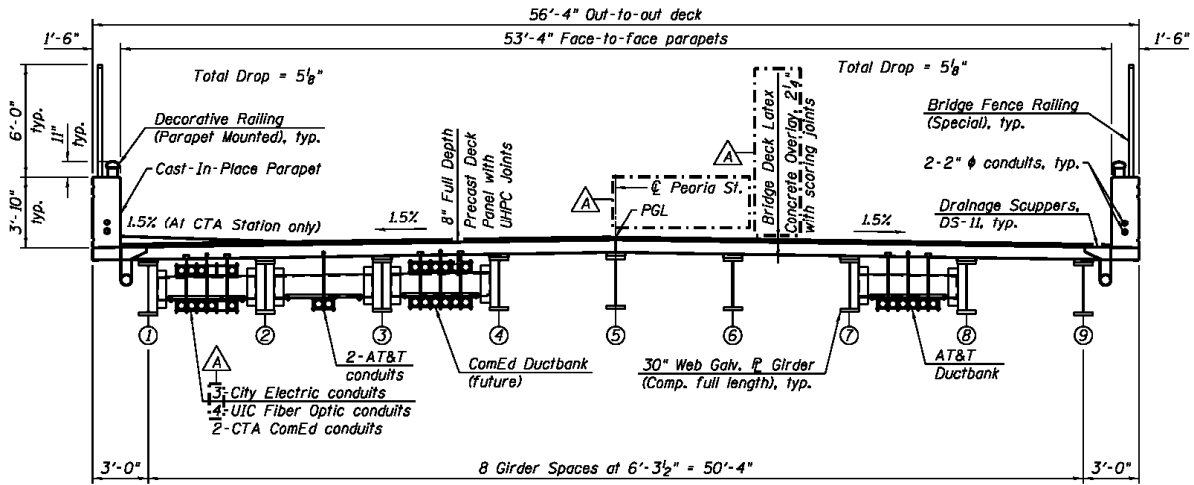

Figure 2. Typical Section

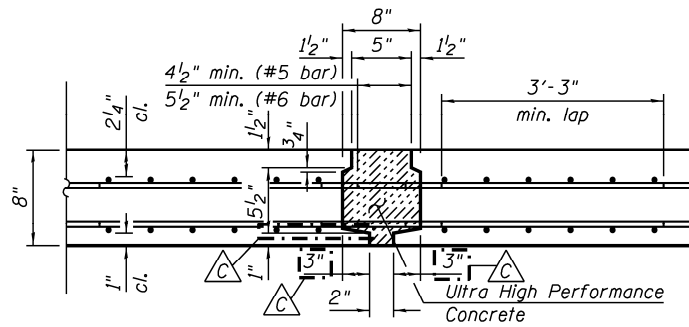

Figure 3. UHPC Transverse Joint

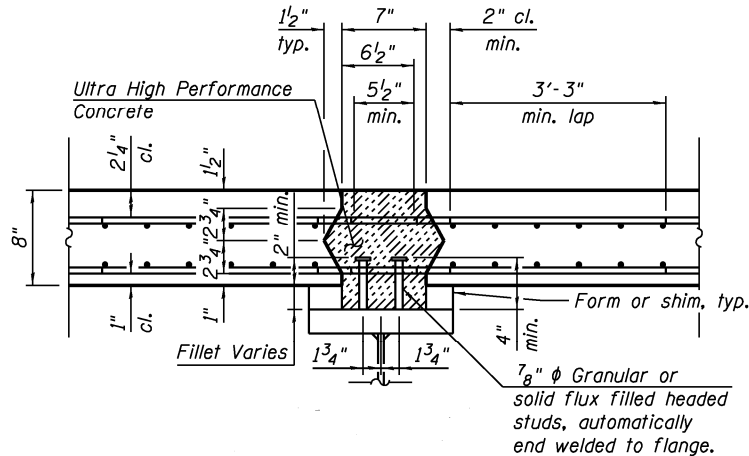

Figure 4. UHPC Longitudinal Joint

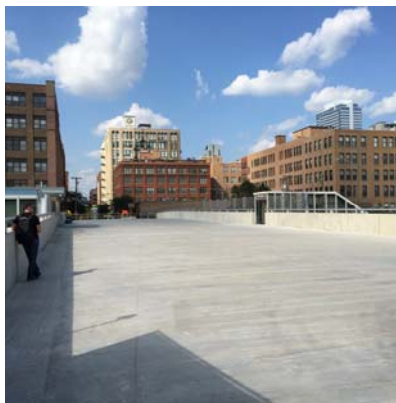



**Figure 7. Casting of Non-Shrink Grout at Shear Stud Pockets**



**Figure 8. Casting of UHPC**



**Figure 9. Completed Bridge**

#### 4. Conclusions

There are four primary characteristics of UHPC that distinguish it from conventional concrete:

- Higher compressive strength.
- Higher tensile strength with ductility.
- Increased durability.
- Higher initial unit cost.

A new deck system developed a few years ago using Precast Deck Panels with UHPC joints has been gaining popularity. This new deck system utilizes the superior characteristics of Ultra High Performance Concrete (UHPC) to simplify the precast panel fabrication and installation processes as opposed to the conventional approach such as internal post-tensioning.

#### 5. References

Badie, S. and Tadros, M., “Full-Depth Precast Concrete Bridge Deck Panel Systems,” NCHRP REPORT 584/Project 12-65, Transportation Research Board, National Research Council, Washington, DC, 2008, pp. 5.

Badie, S. and Tadros, M., “State-of-the-Art Report on Full-Depth Precast Concrete Bridge Deck Panels,” Presentation at PCI Class, Dec. 2011, pp. 64.

FHWA, “Ultra-High Performance Concrete”, Federal Highway Administration Research and Technology, Coordinating, Developing, and Delivering Highway Transportation Innovations, Feb. 2014. Available at <https://www.fhwa.dot.gov/research/resources/uhpc/>

Graybeal, B., “Behavior of Field-Cast Ultra-High Performance Concrete Bridge Deck Connections Under Cyclic and Static Structural Loading”, FHWA Publication No. FHWA-HRT-11-023, 2010.

Graybeal, B., “Design and Construction of Field-Cast UHPC Connections”, FHWA Publication No. FHWA-HRT-14-084, 2014.

He, H., “White Paper: Practical Solutions for Accelerated Bridge Construction with Full Depth Precast Deck Panels”, ACCELBRIDGE, 2011.

#### 6. Acknowledgement

The first author would like to acknowledge Ben Graybeal with FHWA, Vic Perry and Paul White with Lafarge Ductal for providing technical support during the design of the Peoria Street Bridge.