

Implementation of Ultra-High Performance Concrete (UHPC) Decked I-Beam in Ontario

Author(s) & Affiliation:

Maher K. Tadros, Ph.D., P.E., – Professor Emeritus at the University of Nebraska, Principal at e.construct.USA LLC, 11823 Arbor Street Suite 200, Omaha, NE 68144 USA, Phone: 402-884-9998, email: maher.tadros@econstruct.us

Adam Sevenker, M.S., P.E., – Project Engineer, e.construct.USA LLC, 11823 Arbor Street Suite 200, Omaha, NE 68144 USA, Phone: 402-884-9998, email: asevenker@econstruct.us

Don Gardonio – President, FACCA Inc., 2097 County Rd 31, Ruscom Station, ON N0R 1R0, Canada, Phone: 519-975-0377, email: don@facca.com

Philip Loh, M.Eng., P.Eng., – Vice President, Research & Development, Dura Concrete Canada Inc., 2097 County Rd 31, Ruscom Station, ON N0R 1R0, Canada, Phone: 519-975-0377, email: philip@facca.com

Abstract:

The structural engineering firm, e.construct (Omaha, Nebraska, United States), has designed an Ultra-High Performance Concrete (UHPC) decked I-beam to be installed at a new privately-owned vehicular bridge in Shanty Bay, Ontario, Canada for demonstration and evaluation. Through a technology transfer joint venture agreement between FACCA Incorporated (Ruscom, Ontario, Canada) and Dura Technology (Ipoh, Malaysia), the Dura UHPC is batched using local North American raw materials. This paper will focus on development of the UHPC decked I-beam and adjustments that have come about during the on-going implementation process for this Design-Build project. The paper will also list items needing further investigation.

One of the biggest challenges faced thus far has been the creation of formwork that will allow for the top flange waffle deck to be cast simultaneously with the rest of the beam without creation of any cold joints. Economy in utilizing the relatively expensive UHPC and desire to reduce the number of ribs in the top flange resulted in an optimized spacing of 500 mm (20 in.). To keep the rib width to a minimum, high strength corrosion resistant steel, ChrōmX, was introduced. Prototype pieces and small specimens are currently being cast for element testing.

Keywords:

Ultra-High Performance Concrete, UHPC, Precast, Formwork, Waffle Deck

1. Introduction

Ultra-high performance concrete (UHPC) was first introduced as Reactive Powder Concrete in the early 1990's by employees of the French contractor Bouygues (Richard 1994). Since then, much research has been performed by the FHWA (Russell 2013) in the United States, and other countries around the world. In the US, several states have expressed interest in introducing UHPC in their bridge projects, supported by FHWA research as well as research done by their local universities. Most notably Virginia has produced I-beams with UHPC. Iowa has built two bridges with UHPC beams and one with a UHPC deck. A significant interest has recently been directed at using UHPC in longitudinal joints between precast concrete beams.

It appears that the high cost of UHPC has discouraged owners from implementing use of this outstanding material in applications beyond the initial demonstration projects most of which had been subsidized by government technology implementation programs. The exception to this trend has been the significant success of the DURA Technology (DURA) in Malaysia. Over 100 bridges have been built in that country since 2010. Motivated by the success in Malaysia, a number of attempts have been made in the US and Canada to expand the implementation of UHPC beyond the recent applications in joints between precast elements.

The outcome of one of the programs is the focus of this paper. It has been sponsored by the Ontario Contractor, FACCA, Inc., and the engineering design performed by Dr. Tadros, the original developer of the popular NU I-Girder, and his company, e.construct.USA, LLC. The goal was to help convert the NU I-Girder to a product which fully incorporates UHPC. FACCA also engaged Dr. Jackie Voo, of the Malaysian company DURA, to give advice about implementing the technology he has successfully used in Malaysia. Thus, a strong team was formed including the original developer of the NU I-Girder, the most successful implementer of UHPC, and a versatile contractor who has been successful in precasting concrete bridge products and building bridges with them.

This article provides a summary of the development of the UHPC Decked I-Beam (UHPC DIB) covered in a previous paper. However, this article primarily focuses on the creation of formwork and further optimization of the UHPC DIB waffle deck that has occurred since that time. One of the biggest challenges faced thus far has been the creation of formwork that will allow for the top flange waffle deck to be cast simultaneously with the rest of the beam without creation of any cold joints. It discusses the introduction of high strength, corrosion resistant steel, ChrōmX, to further reduce the number of ribs in the top flange resulting in more economy by using less of the relatively expensive UHPC and further utilizing its properties in the design.

2. Background

A beam having the general shape of the NU I-girder was found to be a reasonable starting point. The Federal Highway Administration (FHWA) and the state of Iowa have successfully used a waffle slab deck. This inspired our team to try to use a similar ribbed slab deck system that is integral with the web and bottom flange. Several trials produced the section shown in Figure 1.

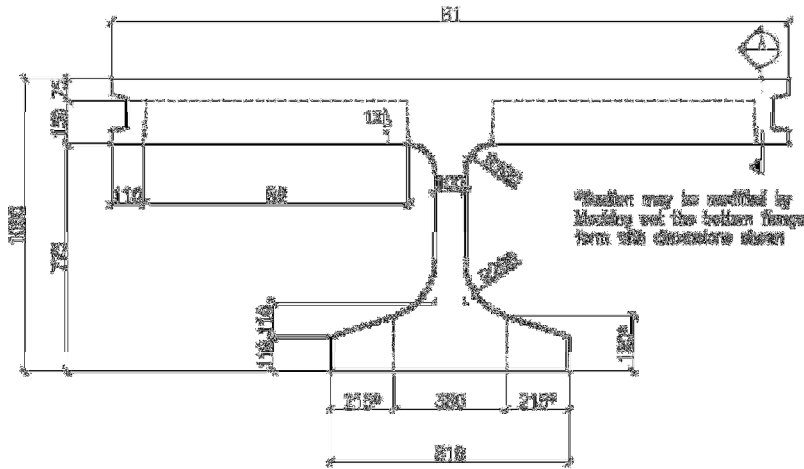

Figure 1. 1000 UHPC Decked I-Beam with Variable Top Flange

As the team attempted to develop the shape to a family of sizes for spans up to 60 m (197 ft), we had to make the top flange large enough to accommodate the longer spans. As a result, it was decided to keep the same shape of top flange, bottom flange and web width. Thus, the variables for various sizes are:

1. The total depth of 1000, 1500, and 2000 mm. Figures 1, 2, and 3, respectively.
2. The top flange width (B1) of 1000, 1500, 2000, 2500 and 3000 mm.
3. The bottom flange can be blocked out to produce a narrow bottom flange in order to save concrete volume for designs that do not require the full bottom flange.

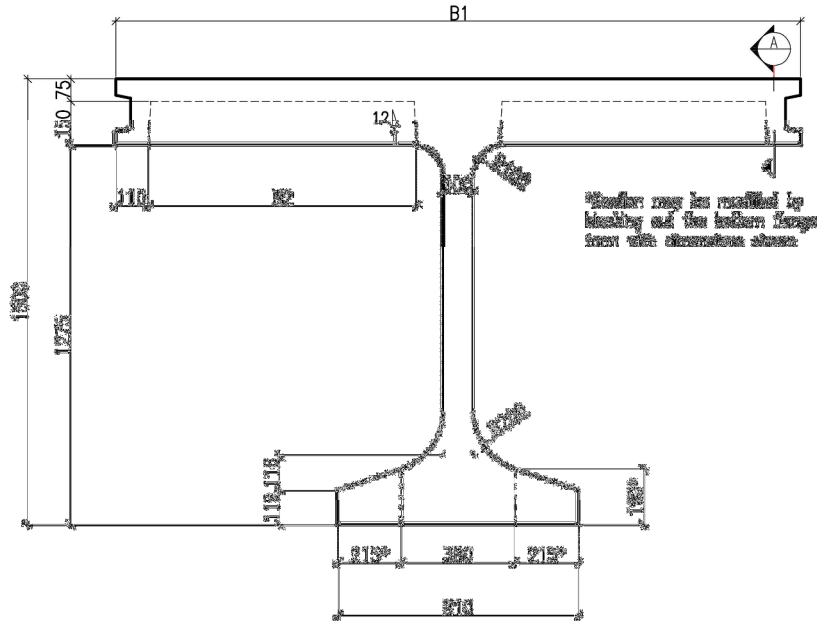

Figure 2. 1500 UHPC Decked I-Beam with Variable Top Flange

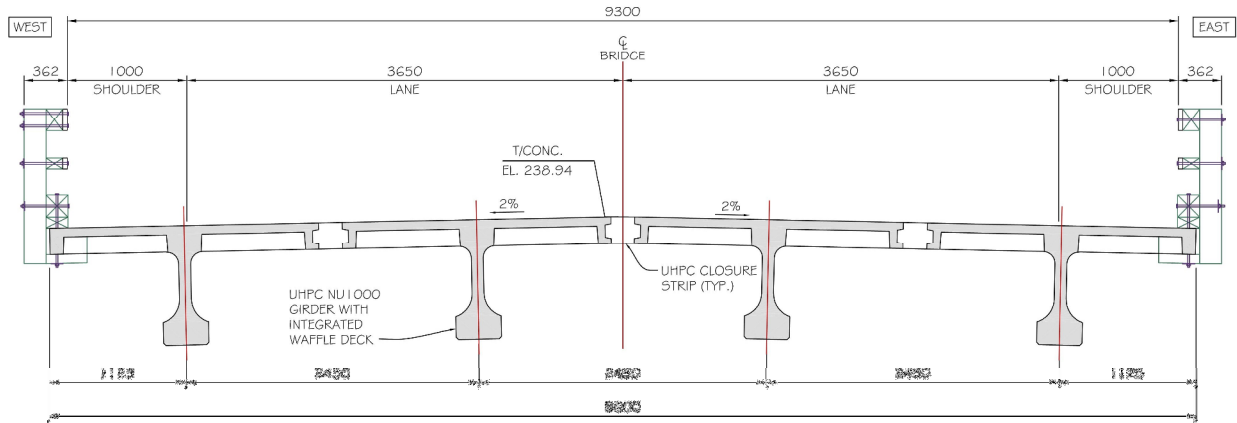

Figure 4. Proposed Bridge Cross Section

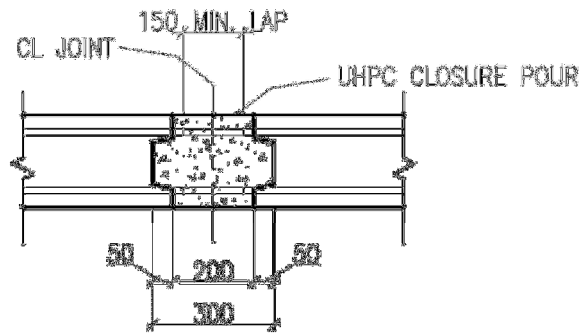

Figure 5. Typical Joint Detail

The integrated deck (top flange) incorporates details of a waffle slab to minimize the quantity of UHPC material. The transverse ribs are spaced at 500 mm (19.7 in.) to house the transverse deck reinforcement and the longitudinal rib locations are based on bridge geometry.

The web has the most significant impact on concrete quantities and girder weights. In some applications in Ontario, typical girder products have webs 150 mm or wider. This product has a web which is reduced to only 100 mm providing just enough space for a single leg vertical bar (stirrup) with sufficient cover on each side; should shear reinforcement be required. For the bridge layout and the load conditions of the demonstration bridge it was found that the beam ends require some conventional reinforcement for local effects due to prestressing, but otherwise no additional shear reinforcement is required.

The bottom flange is designed to be able to hold up to 60 – 15.2 mm (0.6 in.) diameter strands at 40 mm (1.57 in.) spacing, or up to 42 – 17.8 mm (0.7 in.) diameter strands at 50 mm (2.0 in.) spacing. Each girder of the demonstration bridge will only require 14 – 15.2 mm (0.6 in.) diameter prestressed strands. Later, it was decided to block out 215 mm (8.5 in) on each side of the bottom flange from 810 mm (31.9 in.) wide down to 380 mm (15.0 in.). This resulted in two benefits: (1) less UHPC material is required reducing production cost and product weight and (2) the prestress strands are concentrated near the web area reducing local stress distribution and avoiding possible cracking due to splitting forces.

3. Waffle Deck Optimization

The UHPC waffle deck slab is designed to be cast integrally with the girder having concrete ribs spanning in transverse and longitudinal directions. The width of transverse and longitudinal ribs was chosen based on the side cover requirements for the reinforcement with tapering of the rib for easy removal of panel formwork. The longitudinal rib spacing is determined by the bridge layout and the girder spacing. The reinforcement required in the transverse direction determines the transverse rib spacing.

The reinforcement needed to resist the design wheel loads is provided in the ribs in both directions. It has been recommended to limit the transverse spacing to 300 mm (11.8 in.) in order to maintain one rib underneath a wheel at all times and limit any local damage to the flat plate deck element and control cracking of the panel under service loads. However, the authors believe that by further utilizing the material properties of the UHPC and by introducing high strength, corrosion resistant steel, ChrōmX, the design can allow the rib spacing to be increased to 500 mm (19.7 in.). This would further reduce the number of ribs in the top flange resulting in more economy by using less of the relatively expensive UHPC.

The design of the longitudinal beam did not consider the fiber strength of the UHPC as the strength gained from the fibers did not provide significant savings toward the reduction of prestressing strand. However, the waffle deck is conventionally reinforced and does not benefit from prestressing like the longitudinal direction. Therefore, the fiber strength was taken into account for flexural strength design.

The stress-strain compatibility procedure was utilized to determine the nominal moment capacity of a T-beam consisting of one rib and its tributary flat plate deck element. This procedure requires an iterative process and takes advantage of the tensile strength of the UHPC. The stress-strain curve for UHPC was simplified, as shown in Figure 6, where the curve plateaus at an assumed value of 10 MPa (1.5 ksi) and ignores any additional strength from strain hardening. The fibers are then assumed to have an ultimate strain limit where once the fibers reach this limit, they are assumed to lose their effectiveness. This strain limit was assumed to be 0.005.

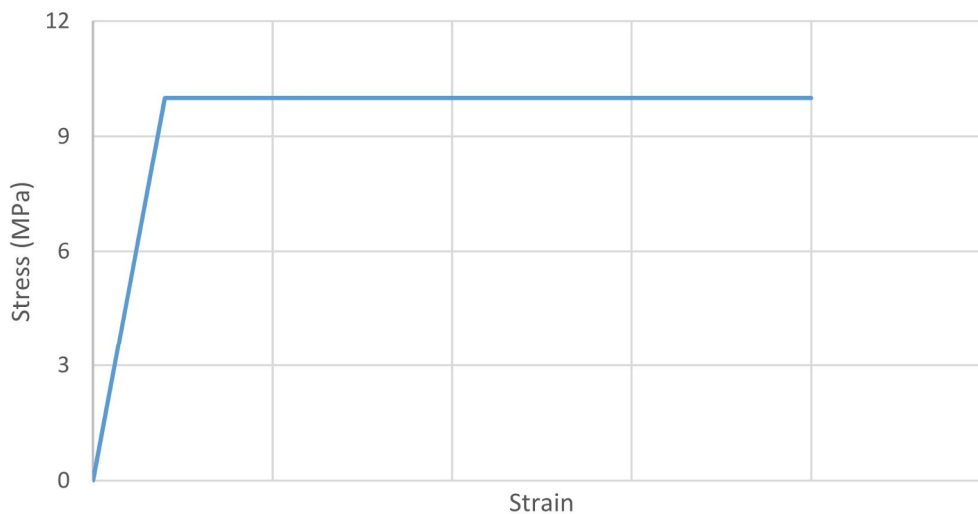

Figure 6. Assumed UHPC Stress-Strain Curve

The flexural analysis showed that 15M (#5) ChrōmX bars at 500 mm (19.7 in.) spacing at the bottom of the rib satisfies transverse positive moment demand due to the design truck.

For negative moment, the flexural analysis has the tension in the relatively wide deck plate and the compression in the stem of the T-beam. The member has typical tension reinforcement in the top plate, there is also concrete tension due to the fibers in the UHPC, as well as concrete compression and compression steel in the stem.

The flexural analysis of this T-beam section led to an interesting result. It was found the stress-strain compatibility calculation resulted in two solutions. There is one equilibrium solution where the neutral axis is near the center of the member. The deck fibers in the top plate have not yet reached their assumed strain limit. Therefore, there is a relatively large amount of UHPC deck fibers in the top plate providing tensile resistance along with the reinforcing steel.

However, there is a second solution where the neutral axis is further down in the stem. As the member is subject to further loading, the fibers in the top plate all reach their assumed strain limit and become ineffective. A small amount of UHPC fibers in the stem then begin to provide tensile resistance along with the now yielded tension reinforcement an equilibrium is once again obtained.

It was determined that the fiber capacity was adequate assuming a relatively low resistance factor. However, for the sake of redundancy, and pending full-scale testing, it was decided to also include 15M (#5) ChrōmX bars at 250 mm (9.8 in.) spacing in the top of the deck.

4. Formwork Development

One of the biggest challenges faced thus far has been the creation of formwork to cast the UHPC DIB. The majority of the challenges came due to the pan molds needed to create the waffle deck voids in the top flange.

Early on it was considered to pour the deck in a first stage casting. This would allow the deck to be cast upside down and the riding surface could be provided with a high-quality form finish. The deck segment would then be positioned on top of the formwork for the web and bottom flange which would be created during a second casting stage. However, this created an unwanted cold joint between the two casting, required complicated dovetail details in order to obtain composite action, and mandated longer production time.

It was highly desirable to come up with a forming system that would allow for the top flange waffle deck to be cast simultaneously with the rest of the beam without creation of any cold joints. The bottom portion of the beam is modeled after the NU I-Girder and retractable forms are easily designed to create this shape, but on typical precast products the top flange is small with some sort of slope/chamfer provided for horizontal form removal. With the UHPC DIB, the top flange is very wide and was chosen to be cast without any slope/chamfer to save on UHPC material, however this does not allow for the forms to be easily removed.

Consequently, the form design incorporated a sloped precast bed to allow the forms to create the separation from the top flange by dropping down vertically as they are pulled back horizontally. In order for the forms to clear the soffit of the top flange, drop-down pan molds were provided. After the concrete sets, locks are released on the outside edge and a hinge on the inside edge allows the pan molds to be pulled down out of the top flange. This formwork concept is illustrated in Figure 7.

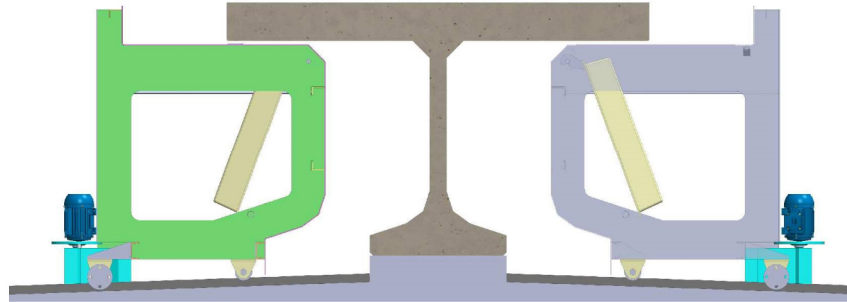

Figure 7. One Stage UHPC DIB Casting Concept

5. Precast Semi-Integral Abutment Diaphragm

Details have been developed to implement a precast semi-integral abutment design with the UHPC Decked I-Beam, see Figure 8. The diaphragm will be a second stage UHPC precast element that will have a vertical joint similar to the one used for the deck, shown in Figure 5. The closure pour will make the diaphragm one continuous element and can be cast at the same time as the deck splice joint. Any reinforcement needed to resist the backfill and compaction pressure against the superstructure will be projected out and spliced using UHPC in the joint closure pour.

In order to transfer the approach slab loads down into the bearings, the loads must be transferred from the diaphragm into the DIB. Smooth UHPC cold joints have very low interface shear capacity. Therefore, trapezoid deformations will be precast into the DIB at both ends of the beam using form liners. The trapezoidal sections will force a shear failure plane to pass through the UHPC engaging the high shear friction capacity of the fibers. Additionally, 6-15M (#5) steel reinforcement will be provided to ensure there is a clamping force between the two elements.

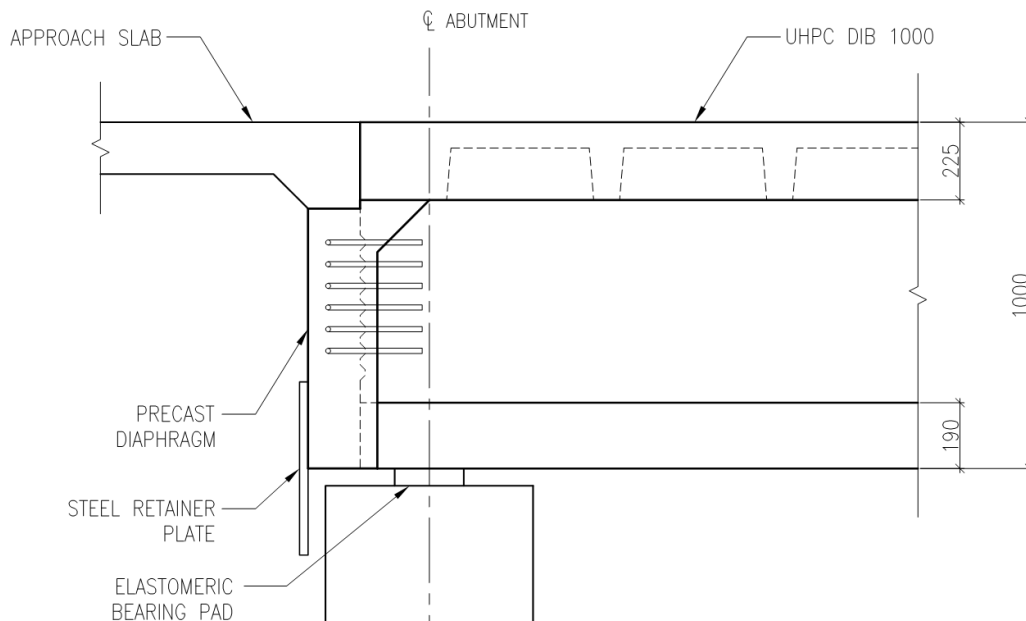

Figure 8. Abutment Detail (Typical reinforcement not shown for clarity)

6. Discussion

The decked I-beam satisfies the design criteria as currently known for UHPC. While certain elements theoretically meet design requirements, they should be tested experimentally. Prototype pieces and small specimens are currently being cast for element testing. The web width of only 100 mm (3.9 in.) is being tested for shear and diagonal tension behavior as well as overturning due to the top heavy nature of the shape. Multiple tests are being conducted of the waffle deck with ribs spaced at 500 mm (19.7 in.) such as punching shear and flexural capacity, both positive and negative, including the closure pour joint capacity.

Construction of the bridge is planned to be completed by the time of this conference. The conference presentation will therefore be expected to show photos of production, handling and erection of the bridge components.

7. Conclusions

The proposed series of UHPC Decked I-Beams (UHPC DIB) is shown to be applicable to spans up to 60 m. These shapes, along with the formwork concepts developed offer ease of production and construction while still providing superior long-term performance.

Summarized below are some specific areas that might be worth further research for a variety of reasons, such as precast production, cost savings or code development.

1. According to FHWA, UHPC should not see load application below 100 MPa (14 ksi) compressive strength. This includes transfer of the strand forces at the time of release. The time required to reach 100 MPa may require the product to remain in the precast bed for several days slowing production turn-around.

2. Tensile strength at release used in calculations was assumed to be proportional to compressive strength gain. According to FHWA, tensile strength within UHPC develops faster than compressive strengths, but no guidance is provided. While debonding of strand was not required in this example, with the proportional tensile strength assumption future products may require debonding unless guidance for using higher tensile strengths is developed.

3. Limited data is available on the punching shear capacity of UHPC. Additional data on punching shear may allow the deck “plate” thickness to be reduced, leading to a significant reduction in the amount of UHPC material required.

4. Further research into prestressing local effects utilizing the tensile strength of UHPC could lead to a reduction of the end bursting and strand confinement reinforcement, specifically the requirements of CSA Article 8.16.3.2.

5. A number of creep tests have indicated that the creep of UHPC is much less than conventional concrete (Russell 2013). Lower creep values will result in reduced prestress losses which can be detrimental if relied on to reduce stresses in restrained members. More testing should be performed to get a better handle on this material property.

6. The capacity provided in the deck overhang seems to justify up to a TL-4. However, testing is recommended before going to the higher level.

References

Aaleti, S., Petersen, B., and Sritharan, S., “Design Guide for Precast UHPC Waffle Deck Panel System, including Connections,” FHWA, U.S. Department of Transportation, Report No. FHWA-HIF-13-032, 2013.

American Association of State Highway and Transportation Officials (AASHTO), “AASHTO LRFD Bridge Design Specifications,” American Association of State Highway and Transportation Officials, 2014.

Canadian Standards Association (CSA), “Canadian Highway Bridge Design Code,” Canadian Standards Association, 2014.

Crane, C., “Shear and Shear Friction of Ultra-High Performance Concrete Bridge Girders,” Diss. Georgia Institute of Technology, 2010.

Graybeal, B., “Characterization of the Behavior of Ultra-High Performance Concrete,” Diss. University of Maryland, 2005.

Graybeal, B., “Ultra-High Performance Concrete,” FHWA, U.S. Department of Transportation, TechNote No. FHWA-HRT-11-038, 2011.

Graybeal, B., “Design and Construction of Field-Cast UHPC Connections,” FHWA, U.S. Department of Transportation, Publication No. FHWA-HRT-14-084, 2014

Richard, P., and Cheyrezy, M.H., “Reactive Powder Concretes with High Ductility and 200-800 MPa Compressive Strength,” American Concrete Institute Special Publication, Vol. 144, 1994, pp. 507-518.

Russell, H. G. and Graybeal, B., “Ultra-High Performance Concrete: A State-of-the-Art Report for the Bridge Community,” FHWA, U.S. Department of Transportation, Report No. FHWA-HRT-13-060, 2013.

Voo, Y. L., Foster, S. J. and Hassan, M. F., “The Current State of Art of Ultra-High Performance Concrete Bridge Construction in Malaysia,” Proceedings of the 12th International Conference on Concrete Engineering and Technology, 2014.

Wille, K., Naaman, A. E., and El-Tawil, S., “Optimizing Ultra-High-Performance Fiber-Reinforced Concrete,” *Concrete International*, Vol. 33, No. 9, 2011, pp. 35-41.

8. Acknowledgements

The authors thank FACCA, Inc., Ontario, for financial support of the study reported in this project. The employees of FAACA have demonstrated ingenuity in creating a forming system for this unique UHPC DIB shape that allows the product to be made in one stage without a “cold” joint. A number of MTO personnel have provided the motive behind the development of the UHPC DIB and continuing support of the progress made so far. William Nickas, Director of Transportation at the Precast Prestressed Concrete Institute (PCI) has been an inspiration and a strong driving force for precast industry adoption of the new and exciting UHPC material in full sized members. Dr. Amgad Girgis and Dr. Micheal Asaad of e.construct contributed valuable information to the development of the UHPC DIB system.